

Fundamentals of Real-Time Spectrum Analysis

Primer

Contents

Chapter 1: Introduction and Overview	3	Timing and Triggers.....	30
The Evolution of RF Signals	3	Real-Time Triggering and Acquisition.....	31
Modern RF Measurement Challenges	4	Triggering in Systems with Digital Acquisition.....	32
A Brief Survey of Instrument Architectures.....	5	Trigger Modes and Features.....	32
The Swept Spectrum Analyzer	5	Real-Time Spectrum Analyzer Trigger Sources	33
Vector Signal Analyzers	7	Constructing a Frequency Mask.....	34
Real-Time Spectrum Analyzers.....	7	Modulation Analysis	35
Chapter 2: How Does the Real-Time Spectrum Analyzer Work?	9	Amplitude, Frequency, and Phase Modulation	35
RF/IF Signal Conditioning	9	Digital Modulation.....	36
Input Switching and Routing Section	10	Power Measurements and Statistics.....	37
RF and Microwave Sections	10	Chapter 3: Correlation Between Time and Frequency Domain Measurements.....	38
Frequency Conversion/IF Section.....	11	Spectrograms.....	38
Digital Signal Processing (DSP) Concepts	12	Swept FFT Analysis.....	40
Digital Signal Processing Path in Real-Time Spectrum Analyzers	12	Time control of acquisition and analysis	41
IF Digitizer	13	Time Domain Measurements.....	42
Corrections	13	Pulse Measurements.....	42
Digital Downconverter (DDC)	13	Chapter 4: Real-Time Spectrum Analyzer Applications	43
IQ Baseband Signals.....	14	Real-Time Analyzers: Laboratory to Field	43
Decimation.....	15	Data Communications: WLAN.....	44
Decimation Filtering.....	15	Data Communications: WPAN	46
Transforming Time Domain Waveforms to the Frequency Domain.....	16	Voice and Data Communications:	
Real-Time Spectrum Analysis.....	17	Cellular Radio.....	48
The RSA306 and Real-Time Analysis	17	Radio Communications.....	48
Relating RTSA to Swept Spectrum Analyzer.....	18	Video Applications	50
RBW on the Real-Time Spectrum Analyzer	18	Spectrum Management and Interference Finding	51
Windowing	19	Device Testing.....	51
Discrete Fourier Transforms (DFT) in the Real-Time Spectrum Analyzer	20	Radar.....	51
Digital Filtering	22	Chapter 5: Terminology	52
Finite Impulse Response (FIR) Filters	22	Glossary.....	52
Frequency Response vs. Impulse Response	22	Acronym Reference.....	53
Numerical Convolution	23		
DPX™ Technology: A Revolutionary Tool for Signal Discovery	25		
Digital Phosphor Display.....	26		
The DPX Display Engine	27		
The DPX Transform Engine.....	29		

Chapter 1: Introduction and Overview

The Evolution of RF Signals

Engineers and scientists have been looking for innovative uses for RF technology ever since the 1860s, when James Clerk Maxwell mathematically predicted the existence of electromagnetic waves capable of transporting energy across empty space. Following Heinrich Hertz's physical demonstration of "radio waves" in 1886, Nikola Tesla, Guglielmo Marconi, and others pioneered ways of manipulating these waves to enable long distance communications. At the turn of the century, the radio had become the first practical application of RF signals. Over the next three decades, several research projects were launched to investigate methods of transmitting and receiving signals to detect and locate objects at great distances. By the onset of World War II, radio detection and ranging (also known as radar) had become another prevalent RF application.

Due in large part to sustained growth in the military and communications sectors, technological innovation in RF accelerated steadily throughout the remainder of the 20th century and continues to do so today. To resist interference, avoid detection, and improve capacity, modern radar systems and commercial communications networks have become extremely complex, and both typically employ sophisticated combinations of RF techniques such as complex and adaptive modulation, bursting and frequency hopping. Designing these types of advanced RF equipment and successfully integrating them into working systems are extremely complicated tasks.

At the same time, the increasingly widespread success of cellular technology and wireless data networks combined with the advancing state of semiconductor technology and packaging has caused the cost of basic RF components to drop significantly over time. This has enabled manufacturers outside of the traditional military and communications realms to embed relatively simple RF devices into all sorts of commodity products. RF transmitters have become so

pervasive that they can be found in almost any imaginable location: consumer electronics in homes, medical devices in hospitals, industrial control systems in factories, and even tracking devices implanted underneath the skin of livestock, pets, and people.

As RF signals have become ubiquitous in the modern world, so too have problems with interference between the devices that generate them. Products such as mobile phones that operate in licensed spectrum must be designed not to transmit RF power into adjacent frequency channels and cause interference. This is especially challenging for complex multi-standard devices that switch between different modes of transmission and maintain simultaneous links to different network elements. Devices that operate in unlicensed frequency bands must be designed to function properly in the presence of interfering signals, and are legally required to transmit in short bursts at low power levels. These new digital RF technologies that involve the combination of computers and RF include wireless LANs, cellular phones, digital TV, RFID and others. These, combined with new advances in Software Defined Radio (SDR) and Cognitive Radio (CR) provide a new path forward and will fundamentally change spectrum allocation methodologies resulting in increased efficiency in the way that the RF spectrum, one of the scarcest commodities, is utilized.

To overcome these evolving challenges, it is crucial for today's engineers and scientists to be able to reliably detect and characterize RF signals that change over time, something not easily done with traditional measurement tools. To address these problems, Tektronix has designed the Real-Time Spectrum Analyzer (RSA), an instrument that can discover elusive effects in RF signals, trigger on those effects, seamlessly capture them into memory, and analyze them in the frequency, time, modulation, statistical and code domains.

This document describes how the RSA works and provides a basic understanding of how it can be used to solve many measurement problems associated with modern RF signals.

Modern RF Measurement Challenges

Given the challenge of characterizing the behavior of today's RF devices, it is necessary to understand how frequency, amplitude, and modulation parameters behave over short and long intervals of time. Traditional tools like Swept Spectrum Analyzers (SA) and Vector Signal Analyzers (VSA) provide snapshots of the signal in the frequency domain or the modulation domain. This is often not enough information to confidently describe the dynamic nature of modern RF signals.

Consider the following challenging measurement tasks:

- Discovery of rare, short duration events
- Seeing weak signals masked by stronger ones
- Observing signals masked by noise
- Finding and analyzing transient and dynamic signals
- Capturing burst transmissions, glitches, switching transients
- Characterizing PLL settling times, frequency drift, microphonics
- Capturing spread-spectrum and frequency-hopping signals
- Monitoring spectrum usage, detecting rogue transmissions
- Testing and diagnosing transient EMI effects
- Characterizing time-variant modulation schemes
- Isolating software and hardware interactions

Each measurement involves RF signals that change over time, often unpredictably. To effectively characterize these signals, engineers need a tool that can discover elusive events, effectively trigger on those events and isolate them into memory so that the signal behavior can be analyzed.

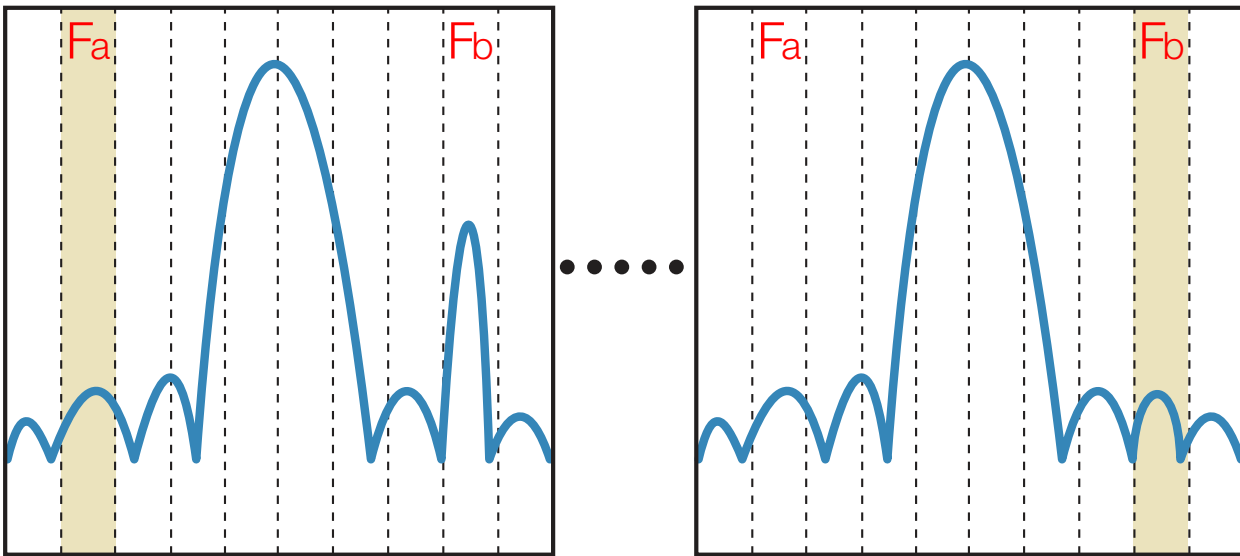

Figure 1-1. The Swept Spectrum Analyzer tunes across a series of frequency segments, often missing important transient events that occur outside the current sweep band highlighted in tan segment Fb on the right.

A Brief Survey of Instrument Architectures

To learn how the RTSA works and understand the value of the measurements it provides, it is helpful to first examine two other types of traditional RF signal analyzers: the Swept Spectrum Analyzer (SA) and the Vector Signal Analyzer (VSA).

The Swept Spectrum Analyzer

The swept-tuned, superheterodyne spectrum analyzer is the traditional architecture that first enabled engineers to make frequency domain measurements many decades ago. Originally built with purely analog components, the SA has since evolved along with the applications that it serves. Current generation SAs include digital elements such as ADCs, DSPs, and microprocessors. However, the basic swept approach remains largely the same and is best suited for observing controlled, static signals. The SA makes power vs. frequency measurements by downconverting the signal of interest and sweeping it through the passband of a resolution bandwidth (RBW) filter. The RBW filter is followed by a detector that calculates the amplitude at each frequency point in the selected span. While this method can provide high

dynamic range, its disadvantage is that it can only calculate the amplitude data for one frequency point at a time. This approach is based on the assumption that the analyzer can complete at least one sweep without there being significant changes to the signal being measured. Consequently, measurements are only valid for relatively stable, unchanging input signals. If there are rapid changes in the signal, it is statistically probable that some changes will be missed. As shown in Figure 1-1, the SA is looking at frequency segment Fa while a momentary spectral event occurs at Fb (diagram on left). By the time the sweep arrives at segment Fb, the event has vanished and is not detected (diagram on right). The SA architecture does not provide a reliable way to discover the existence of this kind of transient signal, thus contributing to the long time and effort required to troubleshoot many modern RF signals. In addition to missing momentary signals, the spectrum of impulse signals such as those used in modern communications and radar may be misrepresented as well. SA architectures cannot represent the occupied spectrum of an impulse without repetitive sweeps. One also needs to pay special attention to sweep rate and resolution bandwidth.

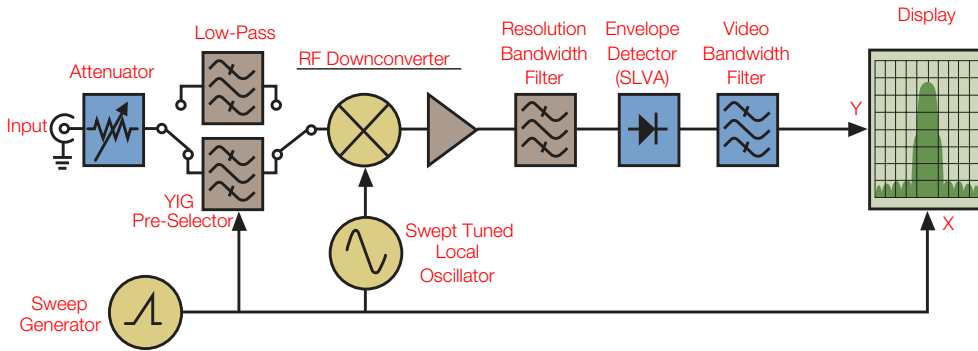

a) Swept Tuned Spectrum Analyzer (SA)

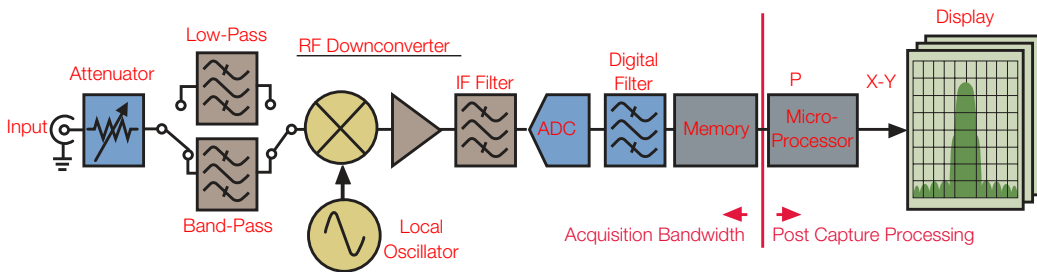

b) Vector Signal Analyzer (VSA)

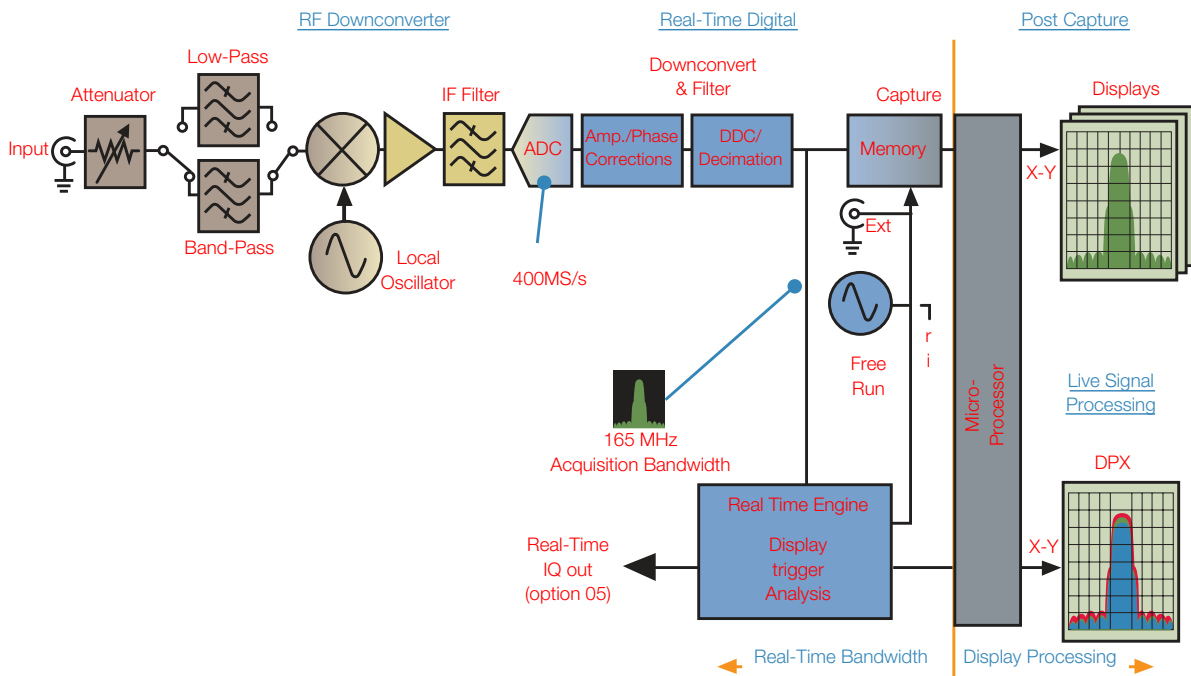

c) Real-Time Spectrum Analyzer (RSA5100 Series)

Figure 1-2 a, b, c. Simplified Block Diagram of Swept Spectrum Analyzer (a), Vector Signal Analyzer (b), and Real-Time Spectrum Analyzer (c).

Figure 1-2a depicts a typical modern SA architecture. Even though modern SAs have replaced analog functionality with digital signal processing (DSP), the fundamental architecture and its limitations remain.

Vector Signal Analyzers

Analyzing signals carrying digital modulation requires vector measurements that provide both magnitude and phase information. A simplified VSA block diagram is shown in Figure 1-2b.

A VSA digitizes all of the RF power within the passband of the instrument and puts the digitized waveform into memory. The waveform in memory contains both the magnitude and phase information which can be used by DSP for demodulation, measurements, or display processing. Within the VSA, an ADC digitizes the wideband IF signal, and the downconversion, filtering, and detection are performed numerically. Transformation from time domain to frequency domain is done using DFT (discrete Fourier transform) algorithms. The VSA measures modulation parameters such as FM deviation, Code Domain Power, and Error Vector Magnitude (EVM and constellation diagrams). It also provides other displays such as channel power, power versus time, and spectrograms.

While the VSA has added the ability to store waveforms in memory, it is limited in its ability to analyze transient events. In the typical VSA free run mode, signals that are acquired must be stored in memory before being processed. The serial nature of this batch processing means that the instrument is effectively blind to events that occur between acquisitions. Single or infrequent events cannot be discovered reliably. Triggering on these types of rare events can be used to isolate these events in memory. Unfortunately VSAs have limited triggering capabilities. External triggering requires prior knowledge of the event in question which may not be practical. IF level triggering requires a measurable change in the total IF power and cannot isolate weak signals in the presence of larger ones or when the signals change in frequency but not amplitude. Both cases occur frequently in today's dynamic RF environment.

Real-Time Spectrum Analyzers

The term “real-time” is derived from early work on digital simulations of physical systems. A digital system simulation is said to operate in real-time if its operating speed matches that of the real system which it is simulating.

To analyze signals in real-time means that the analysis operations must be performed fast enough to accurately process all signal components in the frequency band of interest. This definition implies that we must:

- Sample the input signal fast enough to satisfy Nyquist criteria. This means that the sampling frequency must exceed twice the bandwidth of interest.
- Perform all computations continuously and fast enough such that the output of the analysis keeps up with the changes in the input signal.

Discover, Trigger, Capture, Analyze

The Real-Time Spectrum Analyzer (RTSA) architecture is designed to overcome the measurement limitations of the SA and VSA to better address the challenges associated with transient and dynamic RF signals as described in the previous sections. The RTSA performs signal analysis using real-time digital signal processing (DSP) that is done prior to memory storage as opposed to the post-acquisition processing that is common in the VSA architecture. Real time processing allows the user to discover events that are invisible to other architectures and to trigger on those events allowing their selective capture into memory. The data in memory can then be extensively analyzed in multiple domains using batch processing. The real-time DSP engine is also used to perform signal conditioning, calibration and certain types of analysis.

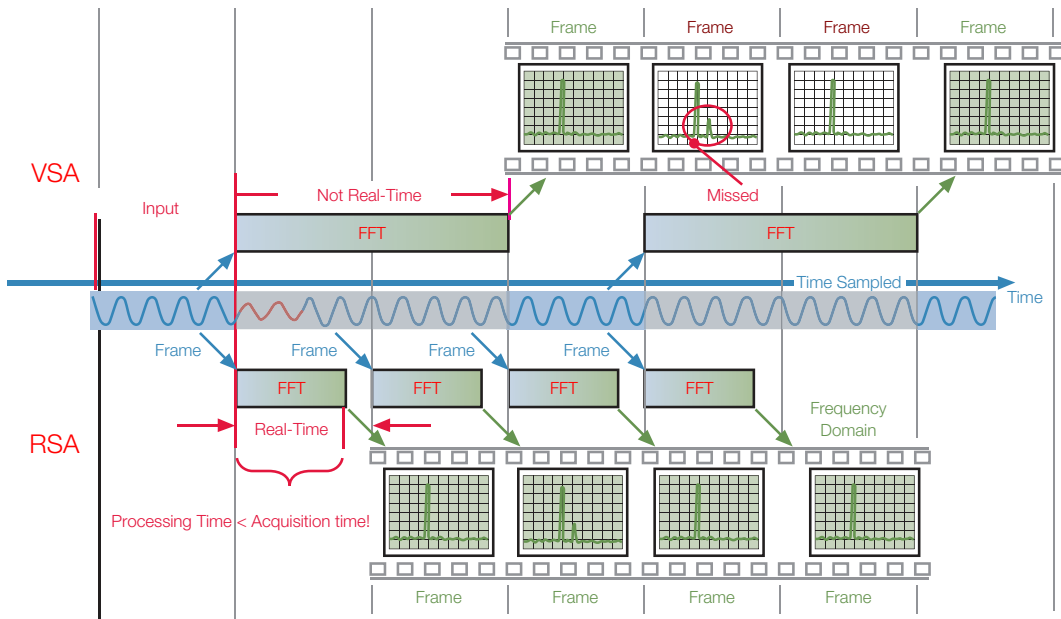

Figure 1-3. VSA processing vs. Real-Time Spectrum Analyzers real-time engine processing.

The heart of the RSA is a real-time processing block as shown in Figure 1-2c (on page 6). Similar to the VSA, a wide capture bandwidth is digitized. Unlike the VSA, the real-time engine operates fast enough to process every sample without gaps as shown in Figure 1-3. Amplitude and phase corrections that compensate for analog IF and RF responses can be continuously applied. Not only can the data stored in memory be fully corrected, but this enables all subsequent real-time processing to operate on corrected data as well. The real-time engine enables the following features that address the needs of modern RF analysis:

- Real-time correction for imperfections in the analog signal path
- DPX® Live RF display allows the discovery of events missed by swept SAs and VSAs
- DPX Density™ measurements and triggering defined by the persistency of a signal's occurrence
- Advanced time-qualified triggering, such as runt triggering, usually found in performance oscilloscopes

- Triggering in the frequency domain with Frequency Mask Trigger (FMT)
- Triggering on user specified bandwidths with filtered power trigger
- Real-time demodulation allowing the user to “listen” to a particular signal within a busy band
- Digital IQ streaming of digitized data allows the uninterrupted output of the signal for external storage and processing

The real-time engine not only enables signal discovery and trigger, but it also performs many of the repetitive signal processing tasks, freeing up valuable software-based resources. Like the VSA, the RSA offers post-acquisition analysis using DSP. It can perform measurements in multiple time-correlated domains that can be displayed simultaneously.

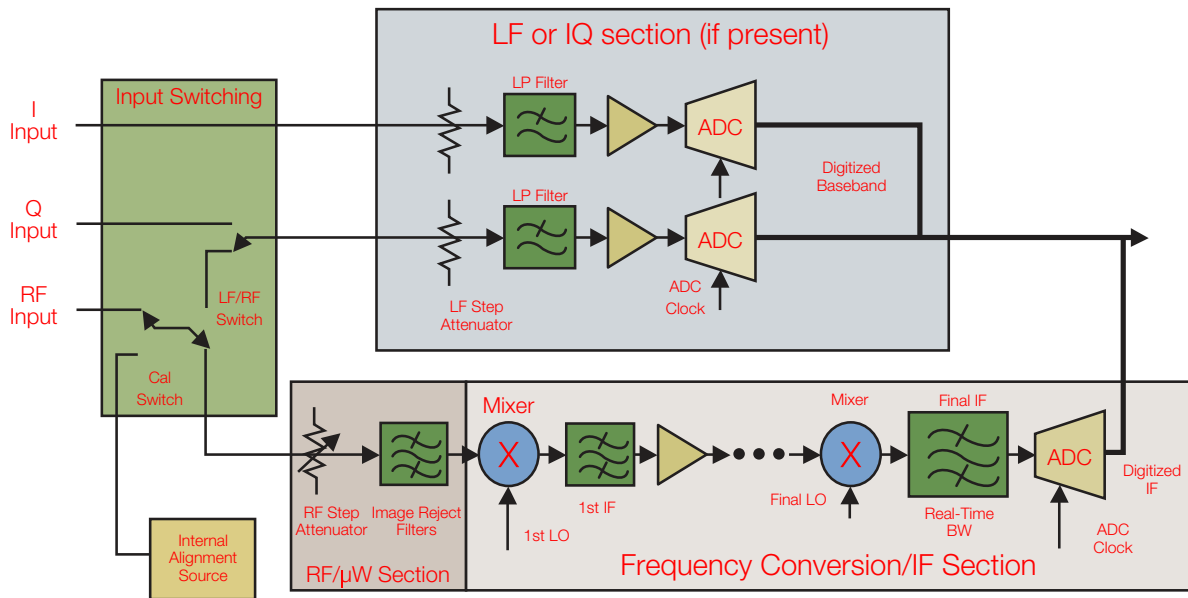

Figure 2-1. Real-Time Spectrum Analyzer RF/IF block diagram.

Chapter 2: How Does the Real-Time Spectrum Analyzer Work?

This chapter contains several architectural diagrams of the main acquisition and analysis blocks of the Tektronix Real-Time Spectrum Analyzer (RSA). Some ancillary functions have been omitted to clarify the discussion.

Modern RSAs can acquire a passband, or span, anywhere within the input frequency range of the analyzer. At the heart of this capability is an RF downconverter followed by a wideband intermediate frequency (IF) section. An ADC digitizes the IF signal and the system carries out all further steps digitally. DSP algorithms perform all signal conditioning and analysis functions.

Several key characteristics distinguish a successful real-time architecture:

- RF signal conditioning that provides a wide-bandwidth IF path and high dynamic range.
- The use of band-pass filters, instead of YIG preselection filters, enabling simultaneous image-free frequency conversion and wideband measurements across the entire input frequency range of each product.
- An ADC system capable of digitizing the entire real-time BW with sufficient fidelity and dynamic range to support the desired measurements.

- A real-time digital signal processing (DSP) engine enables processing with no gaps.
- Sufficient capture memory and DSP power to enable continuous real-time acquisition over the desired time measurement period.
- An integrated signal analysis system that provides multiple analysis views of the signal under test, all correlated in time.

RF/IF Signal Conditioning

Figure 2-1 shows a simplified RSA RF/IF block diagram. Signals with frequency content anywhere in the frequency range of the RSAs are applied to the input connector. Once signals enter the instrument, they are routed and conditioned in accordance with the needs of the analysis selected by the user. Variable attenuation and gain is applied. Tuning is achieved using multi-stage frequency conversion and a combination of tunable and fixed local oscillators (LO). Analog filtering is done at the various IF frequencies. The last IF is digitized with an A/D converter. All further processing is performed using DSP techniques. Some RSA models have optional baseband modes where the input signal is digitized directly, without any frequency conversions. The DSP for baseband signals follows a similar approach as is used with RF signals.

Input Switching and Routing Section

The input switching and routing section distributes the input waveforms to the various signal paths within the instrument. Some RSA models include a separate DC coupled baseband path for increased dynamic range and accuracy when analyzing low frequency signals as well as DC coupled IQ baseband paths. RSAs also include internal alignment sources. These alignment sources, which produce signals with properties that are specifically tailored for the RSA (PRBS, calibrated sinusoids, modulation references, etc.), are used in self-alignment procedures that correct for temperature variations in system parameters such as:

- Gain
- Amplitude flatness across the acquisition bandwidth
- Phase linearity across the acquisition bandwidth
- Time alignment
- Trigger delay calibration

The self-alignment processes, when combined with calibrations using external equipment performed at the factory or the service center, are at the heart of all critical measurement specifications of RSAs.

RF and Microwave Sections

The RF/Microwave section contains the broadband circuitry that conditions the input signals so that they have the proper level and frequency content for optimal downstream processing.

Step Attenuator

The step attenuator is a device composed of resistive attenuator pads and RF/ μ W switches that decreases the level of broadband signals by a programmed amount.

The step attenuator performs two functions:

1. It reduces the level of RF and microwave signals at the input to a level that is optimum for processing. The step attenuator also protects the input from damage due to very high level signals by absorbing excessive RF power.
2. It presents a broadband impedance match over the entire frequency range of the instrument. This impedance match is crucial in maintaining accuracy in measuring RF signals. For this reason, most instrument specifications are stated for the condition of 10 dB or more input attenuation.

Step attenuators used by RSAs vary by model in their design. They typically can be programmed to attenuate from 0 to greater than 50 dB in steps of 5 or 10 dB.

Image Reject Filter

RTSAs provide image-free frequency conversion from the RF and microwave signals at their input to the final IF. This is accomplished by placing a variety of filters in front of the first mixer. The various RTSA models use multi-stage mixing schemes incorporating broadband filters that allow image-free conversion of the entire acquisition bandwidth with repeatable, specified amplitude flatness and phase linearity.

Preamplifier

Some RTSA models include options for a selectable preamplifier that adds gain to the signal path prior to the image reject filter. This option improves the noise figure of the RTSAs and is useful for analyzing very weak signals. Adding gain at the input, of course, limits the largest signal that can be analyzed. Switching this amplifier out of the signal path returns the analyzer's range to normal.

Frequency Conversion/IF Section

All RTSA models can analyze a broad band of frequencies centered anywhere in the analyzer's frequency range. This is done by converting the band of interest to a fixed IF where it is filtered, amplified, and scaled. This IF signal is then digitized. Real-time and batch processing are then used to perform multi-domain analysis on the signals of interest.

Multi-Stage Frequency Conversion

The goal of the frequency conversion section is to faithfully convert signals in the desired band of frequencies to an IF suitable for analog-to-digital conversion. Tuning is accomplished by selecting the frequencies of local oscillators (LO) in a multiple conversion superheterodyne architecture as shown in Figure 2-1 (on page 9). Each frequency conversion stage contains a mixer (analog multiplier) followed by IF filtering and amplification. The choices of IF frequencies, filter shapes, gains, and levels differ depending on RTSA model and indeed are changed within each model as a function of instrument settings in order to optimize performance in several areas, as listed below:

- Spurious responses due to mixer and filter imperfections
- Dynamic range (smallest and largest signals that can be viewed simultaneously without errors)
- Amplitude flatness across the real-time bandwidth
- Phase linearity across the real-time bandwidth
- Delay match between the signal and trigger paths

Internal Alignment Sources

The performance achieved in RTSAs for some characteristics mentioned in the previous bulleted list far exceeds what is practical with analog components. Filter responses, delays and gains vary over temperature and can be different for individual instruments. RTSAs performance is achieved by actually measuring gains, filter shapes and delays and using DSP to compensate for the measured performance. The frequency response and gain variations of the wideband RF components is measured at the factory with calibrated equipment, traceable to National Metrology Institutes such as NIST, NPL, and PTB. This equipment is also used to calibrate the internal alignment sources which in turn provide signals that adjust for the signal path conditions at the time and place where the RTSA is used. RTSAs use two kinds of internal signals:

- A highly accurate, temperature stable sinusoidal signal is used to set the signal path gain at a reference frequency, typically 100 MHz. This signal is the internal RF level reference. It sets the accuracy in measuring RF power at the center of the acquisition bandwidth.
- A calibrated broadband signal is used to measure the amplitude and phase response across the real-time acquisition BW. This signal is the internal channel response reference. It provides the information that allows DSP to compensate for the amplitude, phase and delay variations across the acquisition bandwidth.

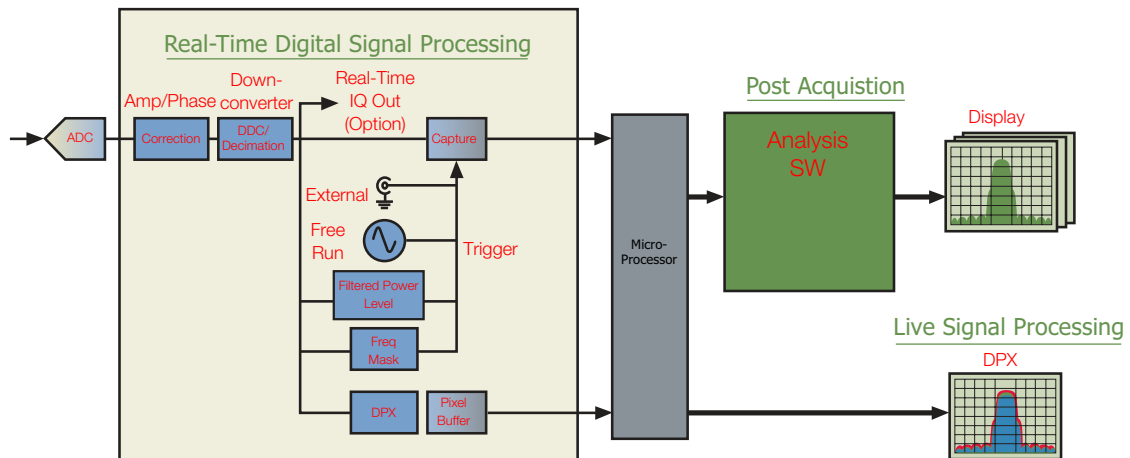

Figure 2-2. Real-Time Spectrum Analyzer Digital Signal Processing Block Diagram.

Digital Signal Processing (DSP) Concepts

This section contains several architectural diagrams of the main acquisition and analysis blocks typical of Tektronix RTSAs. Specific implementations vary by model number and by specific measurement function. Some ancillary functions have been omitted to clarify the discussion.

Digital Signal Processing Path in Real-Time Spectrum Analyzers

Tektronix RTSAs use a combination of analog and digital signal processing (DSP) to convert RF signals into calibrated, time-correlated multi-domain measurements. This section deals with the digital portion of the RTSAs signal processing flow.

Figure 2-2 illustrates the major digital signal processing blocks used in the Tektronix RTSAs. A band of frequencies from the RF input is converted to an analog IF signal that is bandpass filtered and digitized. Corrections are applied to the sampled data correcting for amplitude flatness, phase linearity, and other imperfections of the signal path. Some corrections are applied in real-time, others are applied further downstream in the signal processing path.

A digital downconversion and decimation process converts the A/D samples into streams of in-phase (I) and quadrature (Q) baseband signals as shown in Figure 2-3 (on the next page). This IQ representation of the desired signal is the basic form for representing signals in all RTSAs. DSP is then used to perform all further signal conditioning and measurements. Both real-time DSP and batch mode DSP are used in RTSAs

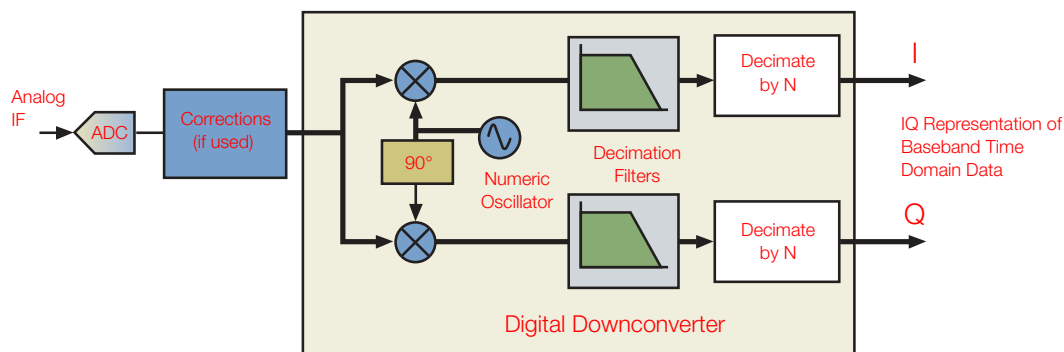

Figure 2-3. IF to IQ conversion in a Real-Time Spectrum Analyzer.

IF Digitizer

Tektronix RTSAs typically digitize a band of frequencies centered on an intermediate frequency (IF). This band of frequencies is the widest frequency for which real-time analysis can be performed. Digitizing at a high IF rather than at DC or baseband has several signal processing advantages: spurious performance, DC rejection, and dynamic range. The sampling rate is chosen so that the desired IF bandwidth fits within a Nyquist zone as shown in Figure 2-4 (on the next page). The sampling rate must be at least twice the IF bandwidth. Sampling without aliasing is possible if the entire IF bandwidth fits between zero and one-half the sampling frequency, one-half and one, three-halves and twice, etc. The practical implementations of IF filters require typical sampling rates at least two-and-a-half times the IF bandwidth.

Corrections

The RTSA specifications for amplitude flatness, phase linearity and level accuracy far exceed what is practical with the components that comprise the analog RF and IF signal conditioning portions of the signal path. Tektronix RTSAs use a combination of factory calibration and internal self-alignment to compensate for analog component variations (temperature, tolerance, aging, etc.) in the signal path.

Factory Calibration

The RF frequency response of the RTSA over its range of input frequencies is measured at the factory. The RF behavior at the center of an acquisition bandwidth is predictable over temperature and does not vary appreciably as the instrument ages. Once measured in the factory, the RF response is stored in a correction table that resides in non-volatile memory.

Internal Alignment

The response across the acquisition bandwidth is affected by the combination of mixers, filters, and amplifiers that comprise the IF processing path. These components can have fine-grain amplitude and phase ripple over the wide bandwidths acquired by RTSAs. An internal alignment process measures the amplitude and phase response as a function of offset from the center frequency. The alignment is done at the time and place where the instrument is in use and can be triggered either manually or as a function of temperature. This response is stored in memory.

Correction Process

The RTSA correction process combines the RF response measured at the factory with the IF response measured during internal alignments to generate FIR coefficients for a set of correction filters that compensate for amplitude flatness and phase response of the entire path between the input connector and the ADC. These correction filters are implemented either in real-time digital hardware or in software-based DSP depending on RTSA model and are applied to the digitized IQ stream.

Digital Downconverter (DDC)

A common and computationally efficient way to represent bandpass signals is to use the complex baseband representation of the waveform.

RTSAs use the Cartesian complex form, representing the time sampled data as I (in-phase) and Q (quadrature) baseband components of the signal. This is achieved using a digital downconverter (DDC) as shown in Figure 2-3.

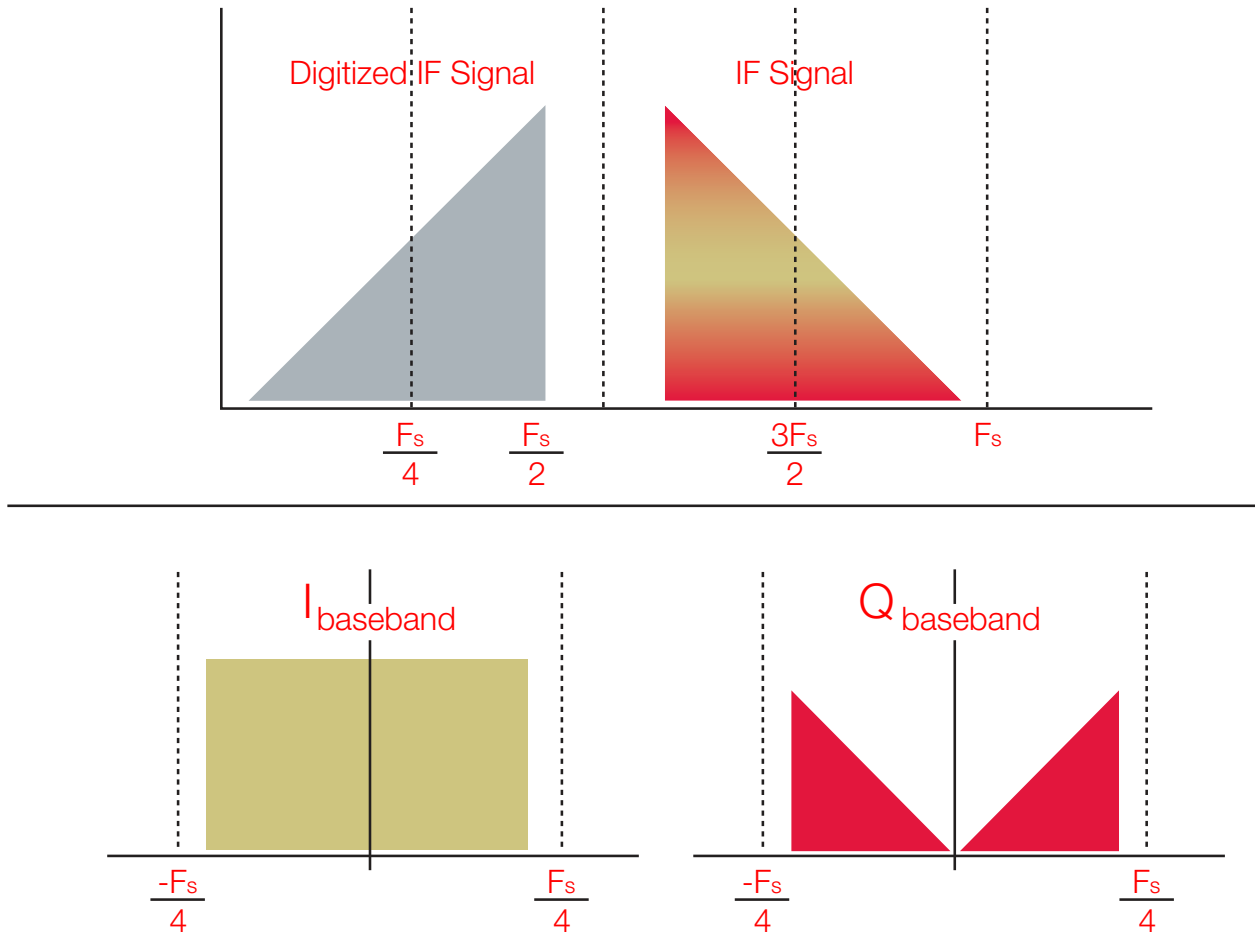

Figure 2-4. Passband information is maintained in I and Q even at half the sample rate.

In general, a DDC contains a numeric oscillator that generates a sine and a cosine at the center frequency of the band of interest. The sine and cosine are numerically multiplied with the digitized IF signal, generating streams of I and Q baseband samples that contain all of the information present in the original IF. DDCs are used not only to convert digitized IF signals to baseband but also in fine frequency tuning in RTSAs.

IQ Baseband Signals

Figure 2-4 illustrates the process of taking a frequency band and converting it to baseband using digital downconversion. The original IF signal in this example is contained in the space

between one half of the sampling frequency and the sampling frequency. Sampling produces an image of this signal between zero and one-half the sampling frequency. The signal is then multiplied with coherent sine and cosine signals at the center of the passband of interest and followed by an anti-aliasing filter, generating I and Q baseband signals. The baseband signals are real-valued and symmetric about the origin. The same information is contained in the positive and negative frequencies. All of the modulation contained in the original passband is also contained in these two signals. The minimum required sampling frequency for each is now half of the original. It is then possible to decimate by two.

Decimation

The Nyquist theorem states that for baseband signals one need only sample at a rate equal to twice the highest frequency of interest. For bandpass signals one needs to sample at a rate at least twice the bandwidth. The sample rate can be reduced when the needed bandwidth is less than the maximum. Sample rate reduction, or decimation, can be used to balance bandwidth, processing time, record length and memory usage. The Tektronix RSA5100B Series, for example, uses a 400 MS/s sampling rate at the A/D converter to digitize a 165 MHz acquisition bandwidth, or span. The I and Q records that result after DDC, filtering and decimation for this 165 MHz acquisition bandwidth are at an effective sampling rate of half the original, that is, 200 MS/s. The total number of samples is unchanged: we are left with two sets of samples, each at an effective rate of 200 MS/s instead of a single set at 400 MS/s. Further decimation is made for narrower acquisition bandwidths or spans, resulting in longer time records for

an equivalent number of samples. The disadvantage of the lower effective sampling rate is a reduced time resolution. The advantages of the lower effective sampling rate are fewer computations for analysis and less memory usage for a given time record.

Decimation Filtering

The Nyquist requirements must also be observed when decimating. If the data rate is reduced by a factor of two, then the bandwidth of the digital signal also must be reduced by a factor of two. This must be done with a digital filter prior to the reduction in sample rate to prevent aliasing. Many levels of decimation are used in Tektronix RTSAs. Each level contains a digital filter followed by a reduction in the number of samples. An additional advantage of decimation and filtering is a reduction in noise with the reduced bandwidth. This reduction in noise is often called processing gain.

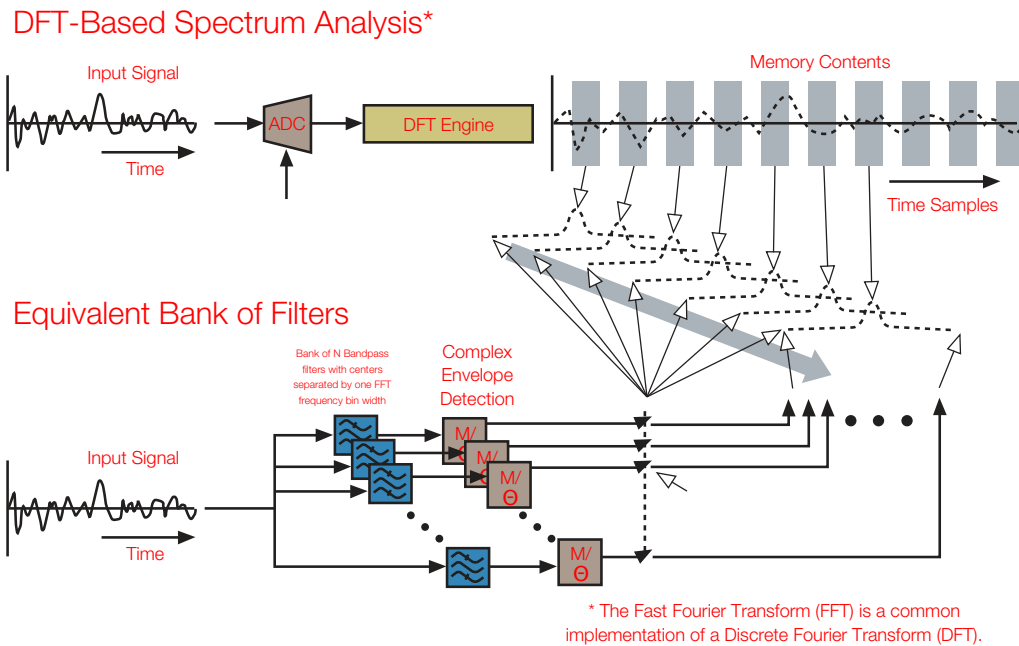

Figure 2-5. A DFT-based Spectrum Analyzer and an equivalent implementation using a bank of bandpass filters.

Transforming Time Domain Waveforms to the Frequency Domain

Spectrum analysis, also called Fourier analysis, separates the various frequency components of an input signal. The typical spectrum analyzer display plots the level of the individual frequency components versus frequency. The difference between the start and stop frequencies of the plot is the span.

Spectrum analysis is said to be real-time when repetitive Discrete Fourier Transforms (DFTs) are performed as shown in Figure 2-5 is such a way that signal processing keeps up with the input signal. Repetitive Fourier transforms can also be used to discover, capture and analyze infrequent transient events in the frequency domain even when the requirements for real-time are not strictly met.

Real-Time Spectrum Analysis

For spectrum analysis to be classified as real-time, all information contained within the span of interest must be processed indefinitely without gaps. An RTSA must take all information contained in time domain waveform and transform it into frequency domain signals. To do this in real-time requires several important signal processing requirements:

- Enough capture bandwidth to support analysis of the signal of interest
- A high enough ADC clock rate to exceed the Nyquist criteria for the capture bandwidth
- A long enough analysis interval to support the narrowest resolution bandwidth (RBW) of interest
- A fast enough DFT transform rate to exceed the Nyquist criteria for the RBW of interest
- DFT rates exceeding the Nyquist criteria for RBW require overlapping DFT frames:
 - The amount of overlap depends on the window function
 - The window function is determined by the RBW

Today's RTSAs, such as the Tektronix 5100 and 6100 series, meet the real-time requirements listed above for Frequency Mask Trigger (FMT) for spans up to their maximum real-time acquisition bandwidth. Triggering on frequency domain events, therefore, considers all the information contained in the selected acquisition bandwidth.

The RSA306 and Real-Time Analysis

Although the Tektronix RSA306 USB spectrum analyzer paired with SignalVu-PC cannot do gapless data processing at the incoming data rate, it can capture and transfer downconverted RF samples at the 112 MHz sampling rate of the ADC. SignalVu-PC can store this data in real time on a fast hard solid state disk, but the software running on a laptop

processor cannot process and display all the received data via DFTs in real time. The RSA306 API software provided with the instrument, however, can transfer this data in real time to another process. If that process is efficient and running on a powerful processor, then the combination of the RSA306 hardware and the processor can truly be a real-time analyzer. In addition, SignalVu-PC can read back the recorded gapless data and do analysis offline on a dataset where no samples are missed.

Discovering and Capturing Transient Events

Another application of fast and repetitive Fourier transforms is the discovery, capture and observation of rare events in the frequency domain. A useful specification is the minimum event duration for 100% probability of capturing a single non-repetitive event. A minimum event is defined as the narrowest rectangular pulse that can be captured with 100% certainty at the specified accuracy. Narrower events can be detected, but the accuracy and probability may degrade. Discovering, capturing and analyzing transients requires:

- Enough capture bandwidth to support analysis of the signal of interest
- A high enough ADC clock rate to exceed the Nyquist criteria for the capture bandwidth
- A long enough analysis interval to support the narrowest resolution bandwidth (RBW) of interest
- A fast enough DFT transform rate to support the minimum event duration

At 3.125M spectrums per second, the DPX Spectrum mode in the RSA5100 Series can detect RF pulses as short as 0.43 microseconds with the full accuracy specifications with 100% probability. A Swept Spectrum Analyzer (SA) with 50 sweeps per second requires pulses longer than 20 milliseconds for 100% probability of detection with full accuracy.

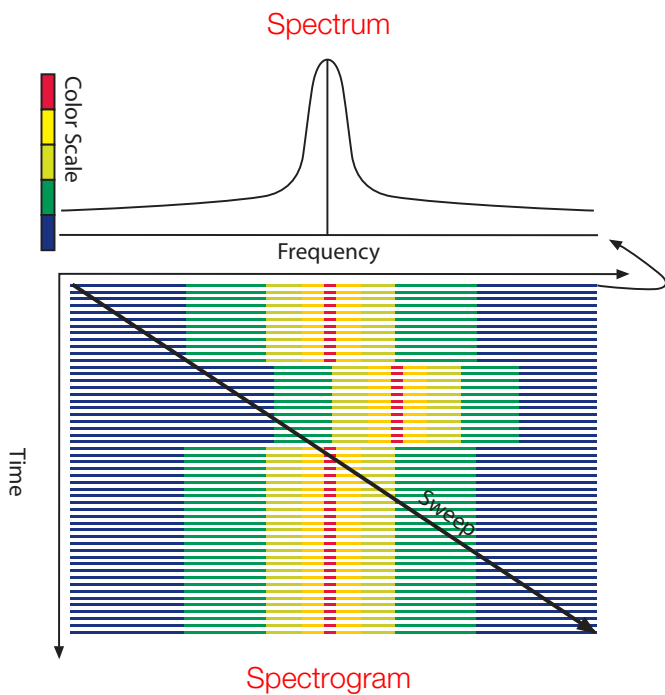

Figure 2-6. Spectrum, Spectrogram and Sweep.

Relating RTSA to Swept Spectrum Analyzer

Consider an RTSA system as described on the previous page. A passband of interest is downconverted to an IF and digitized. The time domain samples are digitally converted to a baseband record composed of a sequence of I (in-phase) and Q (quadrature) samples. DFTs are sequentially performed on segments of the IQ record generating a mathematical representation of frequency occupancy over time, as shown in Figure 2-5 (on page 16).

Taking sequential equally spaced DFTs over time is mathematically equivalent to passing the input signal through a bank of bandpass filters and then sampling the magnitude and phase at the output of each filter. The frequency domain

behavior over time can be visualized as a spectrogram as shown in Figure 2-6, where frequency is plotted horizontally, time is plotted vertically and the amplitude is represented as a color. The real-time DFT effectively samples the entire spectrum of the incoming signal at the rate with which new spectrums are computed. Events occurring between the time segments on which the FFTs are performed are lost. RTSAs minimize or eliminate the “dead time” by performing hardware-based DFTs, often performing transforms on overlapping time segments at the fastest sample rate.

An SA, in contrast, is tuned to a single frequency at any given time. The frequency changes as the sweep advances tracing the diagonal line in Figure 2-6. The slope of the line becomes steeper as the sweep slows so that the function of a spectrum analyzer in zero-span can be represented as a vertical line indicating that the instrument is tuned to a single frequency as time advances. Figure 2-6 also shows how a sweep can miss transient events such as the single frequency hop depicted.

For a discussion of RTSA measurements for frequency spans greater than the real-time bandwidth, please see chapter 3.

RBW on the Real-Time Spectrum Analyzer

Frequency resolution is an important spectrum analyzer specification. When we try to measure signals that are close in frequency, frequency resolution determines the capability of the spectrum analyzer to distinguish between them. On traditional SAs, the IF filter bandwidth determines the ability to resolve adjacent signals and is also called the resolution bandwidth (RBW). For example, in order to resolve two signals of equal amplitude and 100 kHz apart in frequency, RBW needs to be less than 100 kHz.

For spectrum analyzers based on the DFT technique, the RBW is inversely proportional to the acquisition time. Given the same sampling frequency, more samples are required to achieve a smaller RBW. In addition, windowing also affects the RBW.

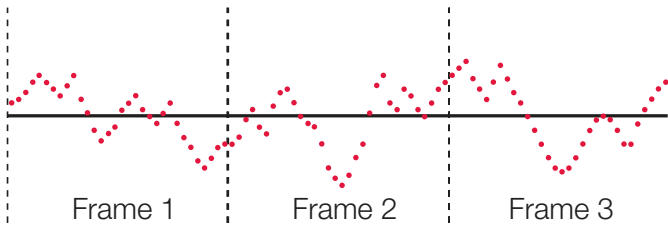

Figure 2-7. Three frames of a sampled time domain signal.

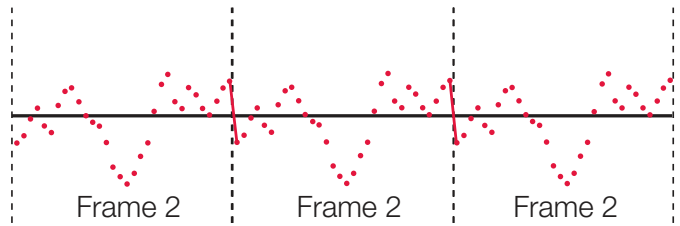

Figure 2-8. Discontinuities caused by periodic extension of samples in a single frame.

Windowing

There is an assumption inherent in the mathematics of Discrete Fourier Transform (DFT) analysis that the data to be processed is a single period of a periodically repeating signal. Figure 2-7 depicts a series of time domain samples. When DFT processing is applied to Frame 2 in Figure 2-7, for example, the periodic extension is made to the signal. The discontinuities between successive frames will generally occur as shown in Figure 2-8.

These artificial discontinuities generate spectral artifacts not present in the original signal. This effect produces an inaccurate representation of the signal and is called spectral leakage. Spectral leakage not only creates signals in the output that were not present in the input, but also reduces the ability to observe small signals in the presence of nearby large ones.

Tektronix Real-Time Spectrum Analyzers apply a windowing technique to reduce the effects of spectral leakage. Before performing the DFT, the DFT frame is multiplied by a window function with the same length sample by sample. The window functions usually have a bell shape, reducing or eliminating the discontinuities at the ends of the DFT frame.

The choice of window function depends on its frequency response characteristics such as side-lobe level, equivalent noise bandwidth, and amplitude error. The window shape also determines the effective RBW filter.

Like other spectrum analyzers, the RTSAs allow the user to select the RBW filter. The RTSAs also allow the user to select among many common window types. The added flexibility to directly specify the window shape enables the users to optimize for specific measurements. Special attention, for example, should be paid to the spectrum analysis of pulse signals. If the pulse duration is shorter than the window length, uniform window (no windowing) should be used to avoid de-emphasizing effects on both ends of the DFT frame. For further information on this topic, please refer to the Tektronix Primer, "Understanding FFT Overlap Processing on the Real-Time Spectrum Analyzer" (37W-18839).

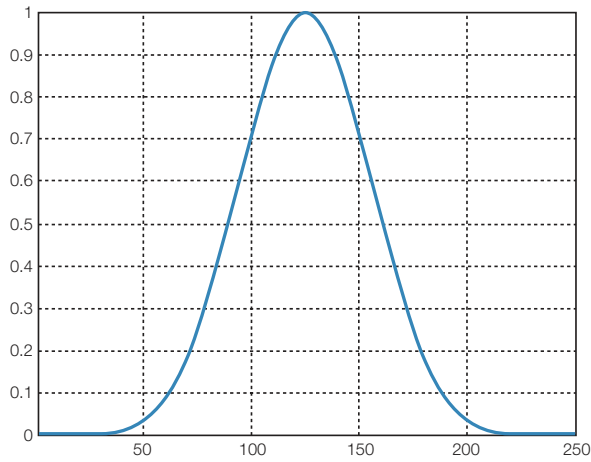

Figure 2-9. Kaiser Window (beta 16.7) in Time Domain (Horizontal is time sample, Vertical is linear scale).

The magnitude of the frequency response of the window function determines the RBW shape. The RBW is defined as the 3 dB bandwidth and is related to the sampling frequency and samples in the DFT as follows:

$$RBW = \frac{k * F_s}{N} \quad \text{Equation 1}$$

$$N = \frac{k * F_s}{RBW} \quad \text{Equation 2}$$

Where k is a window-related coefficient, N is the number of time-domain samples used in the DFT calculation, and F_s is the sampling frequency. For the Kaiser window with $\beta = 16.7$, k is about 2.23. The RBW shape factor, defined as the frequency ratio between the spectrum amplitude at 60 dB and 3 dB, is about 4:1. On the RSA5100/6100, the spectrum analysis measurement uses Equation 2 to calculate the required number of samples for the DFT based on the input span and RBW settings.

The time domain and the spectrum of the Kaiser window used for spectrum analysis is shown in Figure 2-9 and Figure 2-10. This is the default window used in the RSA5100/6100 for spectrum analysis. Other windows (such as Blackman-Harris, Uniform, Hanning) may be user-selected to meet special measurement requirements, and may be used by the instrument when performing some of the measurements available in the instrument.

Vertical Linear Scale

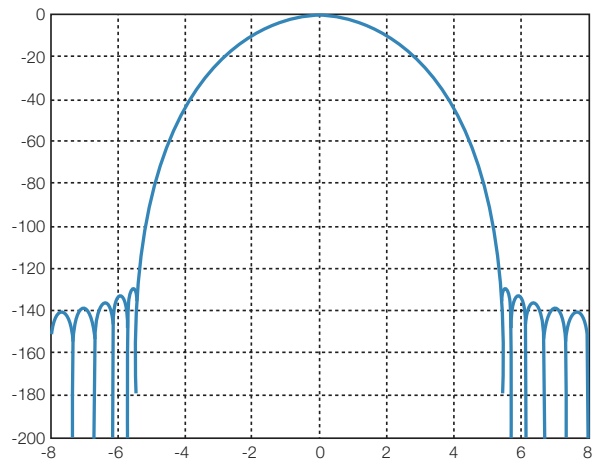

Figure 2-10. The spectrum of a Kaiser window (beta 16.7). The horizontal scale unit is the frequency bin (F_s/N). The vertical scale is in dB.

Discrete Fourier Transforms (DFT) in the Real-Time Spectrum Analyzer

The DFT is defined below:

$$X[k] = \sum_{n=0}^{N-1} x(n) e^{-j2\pi kn / N}$$

from the input sequence $x(n)$. The DFT is block-based and N is the total sample number of each DFT block (or Frame). The input sequence $x(n)$ is a sampled version of the input signal $x(t)$. Although the input sequence is only defined for integer values of n , the output is a continuous function of k , where $k = (N\omega) / (2\pi)$ and ω is the frequency in radians. The magnitude of $X[k]$ represents the magnitude of the frequency component at frequency ω that is present in the input sequence $x(n)$.

There are various efficient methods to compute the DFT. Examples include the Fast Fourier Transform (FFT) and the Chirp-Z Transform (CZT). The choice of implementation method depends on the particular needs of the application. The CZT, for example, has greater flexibility in choosing the frequency range and the number of output points than the FFT. The FFT is less flexible but requires fewer computations. Both the CZT and the FFT are used in RTSAs.

[Reference 1] Oppenheim, A.V. and R.W. Schaffer, Discrete-time Signal Processing, Prentice-Hall, 1989, p. 453.

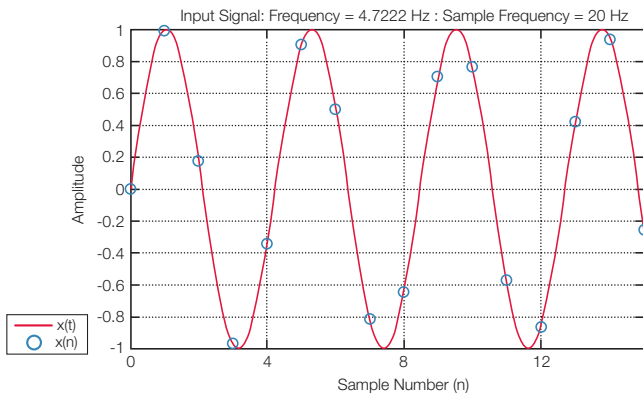

Figure 2-11. Input Signal.

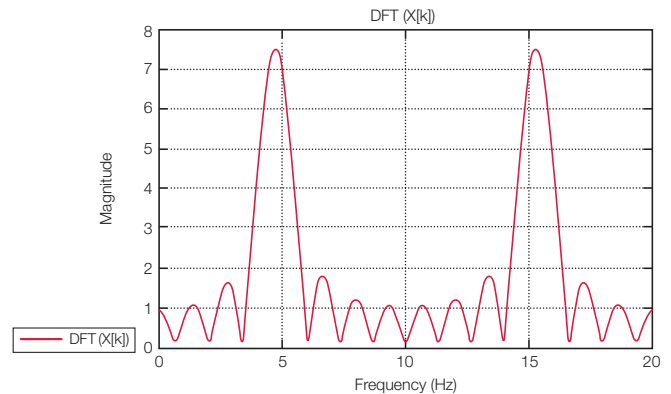

Figure 2-12. DFT of $x(n)$ evaluated continuously.

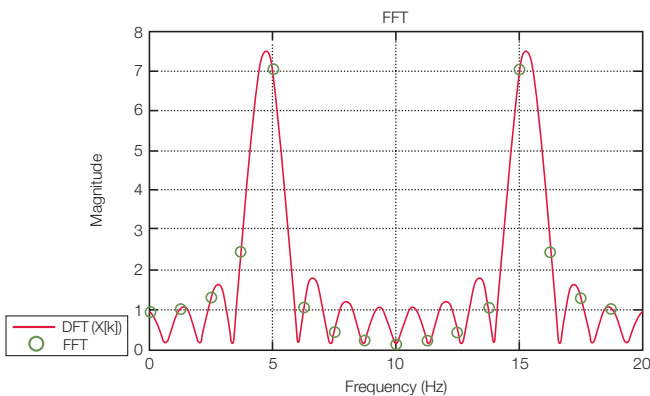

Figure 2-13. FFT of $x(n)$, length of FFT = N = length of $x(n)$.

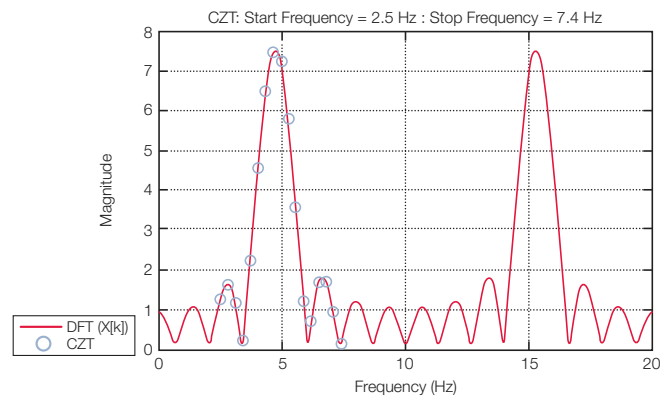

Figure 2-14. CZT of $x(n)$.

The ability to resolve frequency components is not dependent on the particular implementation of the DFT and is determined by the time length of the input sequence or the RBW.

To illustrate the relationship of the DFT to the FFT and the CZT, a sampled Continuous Waveform (CW) signal will be analyzed. For illustration purposes a real-valued sine wave $x(t)$ will be used as the input signal (Figure 2-11). The sample version of $x(t)$ is $x(n)$. In this case $N = 16$ and the sample rate is 20 Hz.

Figure 2-12 shows the result of evaluating the DFT for $0 \leq k < N$. Note that the magnitude of $X[k]$ for $\omega > \pi$ ($f > 10$ Hz) is a mirror image of the first half. This is the result for a real-valued input sequence $x(n)$. In practice, the results from $\pi < \omega < 2\pi$ are discarded (or not computed) when a real input signal is analyzed. For a complex input, a unique result can be obtained for $0 \leq \omega < 2\pi$ ($0 \leq f < 20$ Hz).

An FFT returns N -equally spaced frequency domain samples of $X[k]$. The magnitude of $X[k]$ is shown in Figure 2-13. Note that the samples returned by the FFT might miss the peaks of magnitude of $X[k]$.

A CZT can return M frequency domain samples with an arbitrary start and stop frequency (Figure 2-14). Notice that the CZT does not change the underlying frequency domain output of the DFT. It only takes a different set of frequency domain samples than the FFT.

An advantage of using the CZT is that the frequency of the first and last sample in the frequency domain can be arbitrarily selected and does not depend on the input sample rate. The same result can also be achieved by arbitrarily controlling the input sample rate so that the output of the FFT produces the same output samples as the CZT. The end result is the same in both cases. The choice is purely an implementation issue, and depending on the requirements and available HW, one or the other will be a more optimal solution.

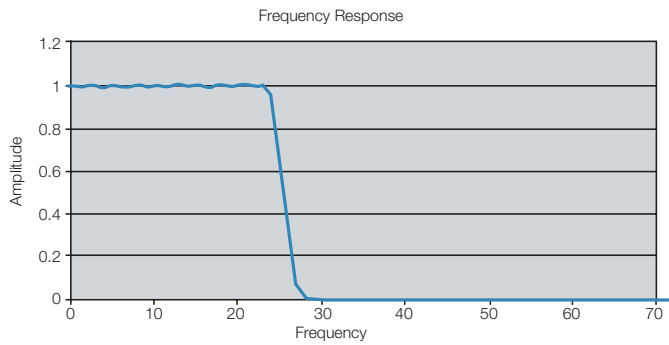

Figure 2-15. Frequency response of a lowpass filter.

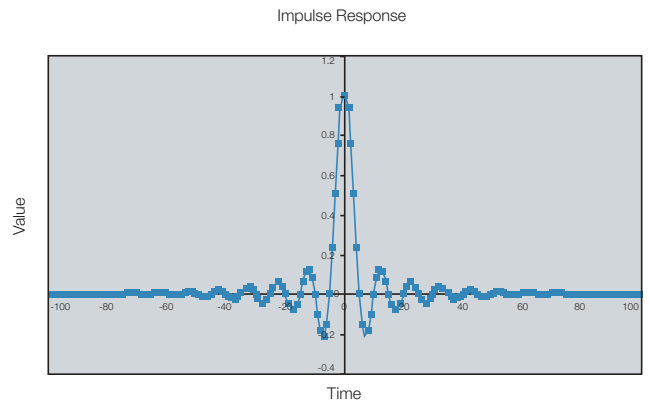

Figure 2-16. Impulse response for the lowpass filter in Figure 2-15.

Digital Filtering

Finite Impulse Response (FIR) Filters

Frequency filters are used in many applications to select some frequencies and reject others. While traditional filters are implemented using analog circuit elements (RLC), DSP selects the frequencies to be enhanced or attenuated mathematically. A common mathematical implementation is the Finite Impulse Response (FIR) filter. RSAs make extensive use of FIR filters. In addition to the usual signal conditioning applications requiring the passage or rejection of specific bands, FIR filters are also used to adjust for analog signal path imperfections. Internally generated alignment data is combined with stored factory calibration data to create FIR filters with a response that compensates for the analog signal path frequency response, making the cascade of the analog and digital paths have flat amplitude response and linear phase.

Frequency Response vs. Impulse Response

The theory of Fourier transforms shows an equivalency between the frequency domain and the time domain. It further tells us that the transfer function of a device, usually expressed as its amplitude and phase response over frequency, is equivalent to the impulse response over time. A FIR filter emulates the impulse response of the desired filter transfer function with a discrete-time approximation that has finite timeduration. Signal filtering is then performed by convolving the input signal with the impulse response of the filter.

Figure 2-15 shows the magnitude of the transfer function of a lowpass filter. Figure 2-16 shows its impulse response.

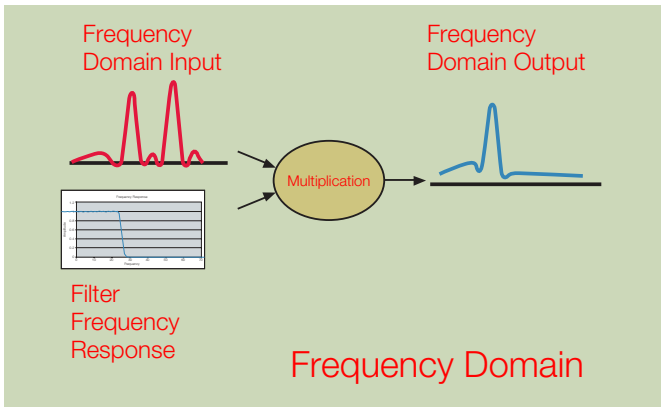

Figure 2-17. Multiplying a filter by its frequency response.

Numerical Convolution

The frequency domain is often used to analyze the responses of linear systems such as filters. Signals are expressed in terms of their frequency content. The spectrum of the signal at the output of a filter is computed by multiplying the input signal spectrum by the frequency response of the filter. Figure 2-17 illustrates this frequency domain operation.

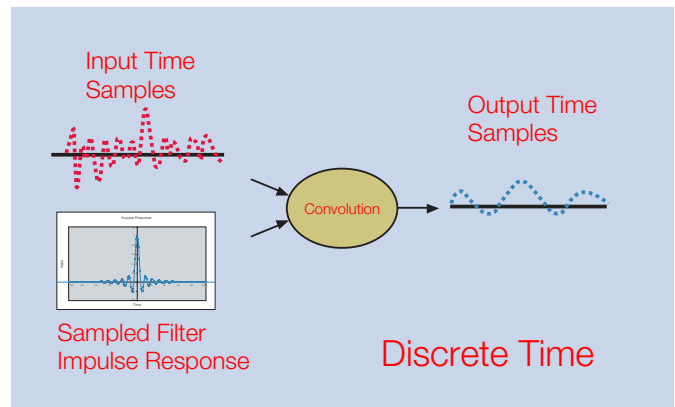

Figure 2-18. Convolution in the time domain is equivalent to multiplication in the frequency domain.

Fourier theory states that a multiplication in the frequency domain is the equivalent of a convolution in the time domain. The frequency domain multiplication shown above is equivalent to convolving the time domain representation of the input signal with the impulse response of the filter as shown in Figure 2-18.

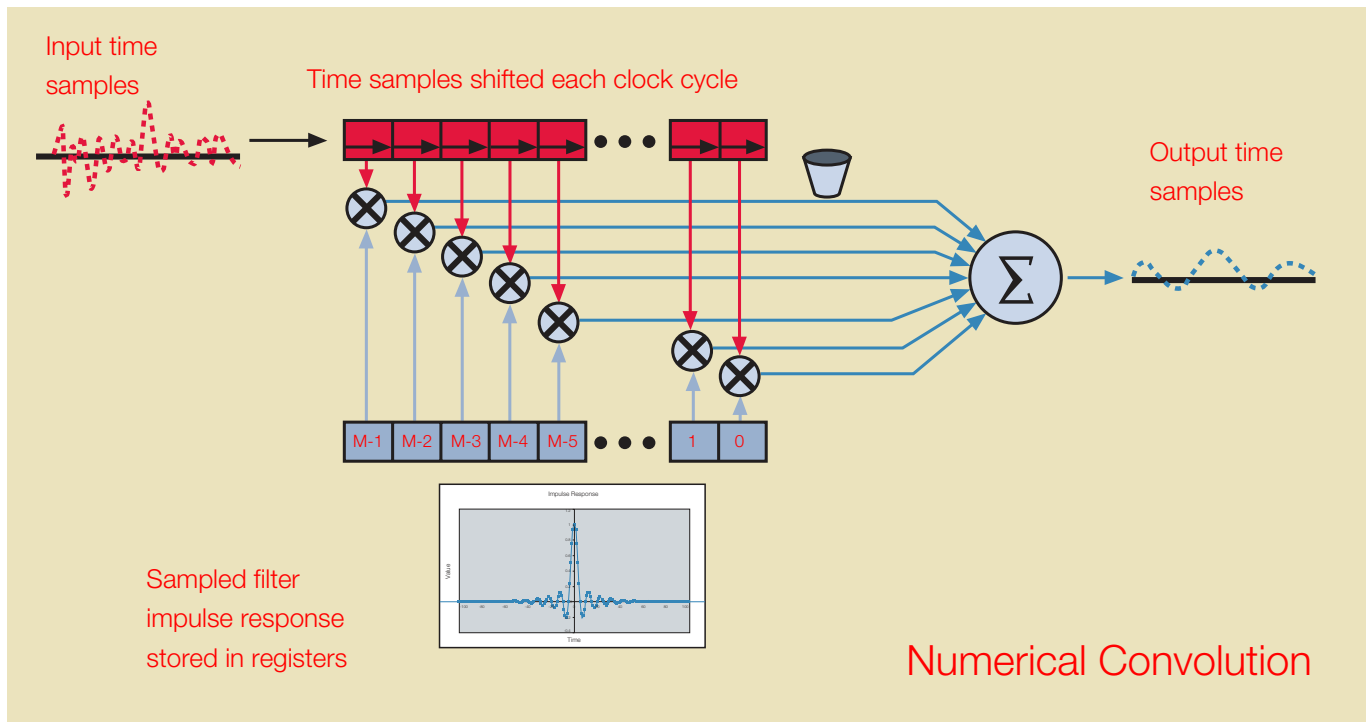

Figure 2-19. Discrete Time Numerical Convolution.

All frequency filters involve the use of memory elements. Capacitors and inductors, the common reactive elements used in analog filters, have memory since their output in a circuit depends on the current input as well as the input at previous points in time. A discrete time filter can be constructed using actual memory elements as shown in Figure 2-19.

The lower registers are used to store values of the filter's impulse response with the earlier samples on the right and the later samples on the left. The upper registers are used to shift the input signal from left to right with one shift each clock cycle. The contents of each corresponding register are multiplied together and all of the resulting products are summed each clock cycle. The result of the sum is the filtered signal.

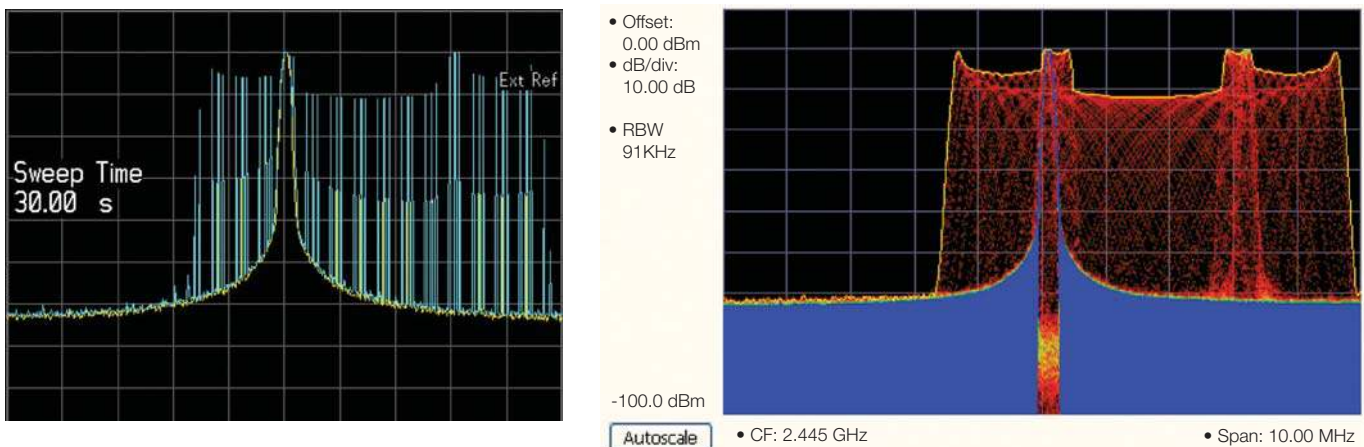

Figure 2-20 a, b. Comparison (a), Swept Spectrum Analyzer MaxHold trace after 120 seconds and (b), Tektronix Real-Time Spectrum Analyzer with DPX bitmap MaxHold trace after 20 seconds.

In summary, the RTSA relies heavily on digital signal processing for spectrum analysis. Key points of DSP as applied to the RTSAs are:

- The RSA5100/6100 analyzers use a combination of FFTs and CZTs to achieve spectrum displays.
- FFTs are more computationally efficient, allowing faster transform rates, but CZTs are more flexible, allowing variable resolution bandwidths for a fixed set of input samples.
- The resolution bandwidth (RBW) shape is achieved by applying an optimized window function to the time domain signals before performing a Fourier transform. RBWs are specified by their 3 dB bandwidth and 60 dB:3 dB shape factor, in the same fashion as an analog implementation. In general, the shape factor of the digitally implemented filter is lower (sharper) than an analog implementation, yielding easier resolution of closely spaced signals of widely different amplitudes.
- Other shape factors can be used for special applications by applying optimized window functions.
- The RSA306 RTSA uses CZTs for maximum flexibility in choosing spectrum lengths and resolution bandwidths. The DSP processing in this instrument is implemented in software on the host PC to allow extremely low power operation in a portable instrument. Processing power in current laptop computers is slower than that in dedicated hardware, so the 100% probability of intercept for a pulse is limited to pulses longer than 100 μ s. As portable computer processing power increases (including implementation of GPUs for fast graphics processing), this number can be reduced.

As we have seen in this section, digitally implemented corrections and filtering are a key factor in implanting the high transform rate required of a RTSA. The next section looks at the practical use of these filters in one of the unique displays available in the RTSA, the Digital Phosphor Spectrum Display.

DPX™ Technology: A Revolutionary Tool for Signal Discovery

Tektronix' patented Digital Phosphor technology or DPX reveals signal details that are completely missed by conventional spectrum analyzers and VSAs (Figure 2-20). The DPX Spectrum's Live RF display shows signals never seen before, giving users instant insight and greatly accelerating problem discovery and diagnosis. DPX is a standard feature in all Tektronix RTSAs.

Digital Phosphor Display

The name “Digital Phosphor” derives from the phosphor coating on the inside of cathode ray tubes (CRTs) used as displays in older televisions, computer monitors and test equipment where the electron beam is directly controlled by the input waveform. When the phosphor is excited by an electron beam, it fluoresces, lighting up the path drawn by the stream of electrons.

Liquid Crystal Displays (LCDs) replaced CRTs in most applications due to their smaller depth and lower power requirements, among other advantages. However, the combination of phosphor coatings and vector drawing in CRTs provided several valuable benefits.

Persistence: The phosphor continues to glow even after the electron beam has passed by. Generally, the fluorescence fades quickly enough that viewers don’t perceive it lingering, but even a small amount of persistence will allow the human eye to detect events that would otherwise be too short to see.

Proportionality: The slower the electron beam passes through a point on the phosphor-coated screen, the brighter the resulting light. Brightness of a spot also increases as the beam hits it more frequently. Users intuitively know how to interpret this z-axis information: a bright section of the trace indicates a frequent event or slow beam motion, and a dim trace results from infrequent events or fast-moving beams. In the DPX display, both color and brightness provide z-axis emphasis.

Persistence and proportionality do not come naturally to instruments with LCDs and a digital signal path. Tektronix developed Digital Phosphor technology so the analog benefits of a variable persistence CRT could be achieved, and even improved upon, in our industry-leading digital oscilloscopes and now in our RTSAs. Digital enhancements such as intensity grading, selectable color schemes and statistical traces communicate more information in less time.

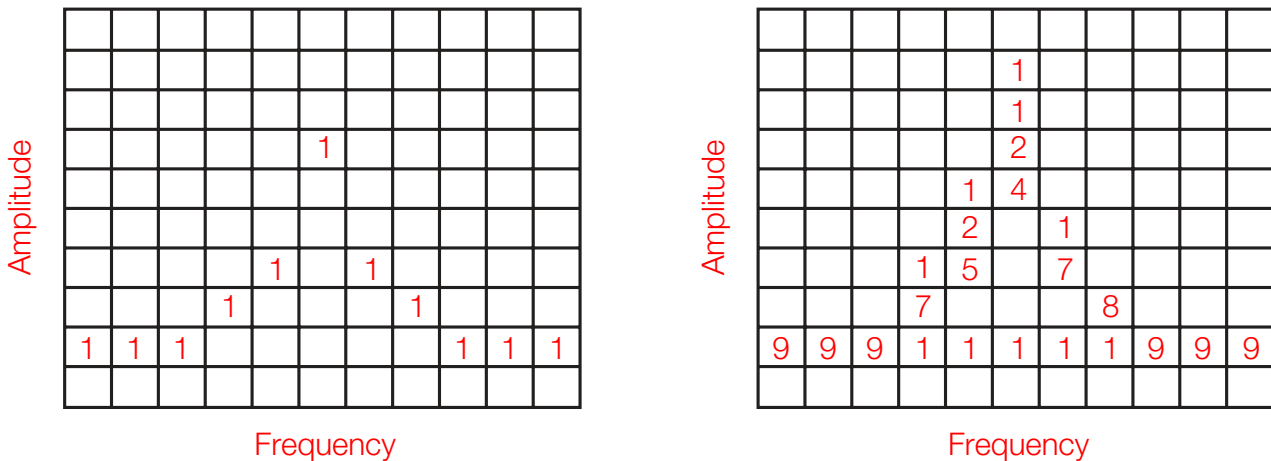

Figure 2-21. Example 3-D Bitmap Database after 1 (left) and 9 (right) updates. Note that each column contains the same total number of “hits.”

The DPX Display Engine

Performing thousands of spectral measurements per second and updating the screen at a live rate is an oversimplified description of the role DPX technology performs in an RTSA. Thousands of acquisitions are taken and transformed into spectrums every second. This high transform rate is the key to detecting infrequent events, but it is far too fast for the LCD to keep up with, and it is well beyond what human eyes can perceive. So the incoming spectrums are written into a bitmap database at full speed then transferred to the screen at a viewable rate. Picture the bitmap database as a dense grid created by dividing a spectrum graph into rows representing trace amplitude values and columns for points on the frequency axis. Each cell in this grid contains the count of how many times it was hit by an incoming spectrum. Tracking these counts is how Digital Phosphor implements proportionality, so you can visually distinguish rare transients from normal signals and background noise.

The actual 3-D database in an RTSA contains hundreds of columns and rows, but we will use an 11X10 matrix to illustrate the concept. The picture on the left in Figure 2-21 shows what the database cells might contain after a single spectrum is mapped into it. Blank cells contain the value zero, meaning that no points from a spectrum have fallen into them yet.

Number of Occurrences	Color
0	black
1	blue
2	light blue
3	cyan
4	green blue
5	green
6	yellow
7	orange
8	red orange
9	red

Figure 2-22. Example Color-Mapping Algorithm.

The grid on the right shows values that our simplified database might contain after an additional eight spectral transforms have been performed and their results stored in the cells. One of the nine spectrums happened to be computed at a time during which the signal was absent, as you can see by the string of “1” values at the noise floor.

When we map the Number of Occurrences values to a color scale, data turns into information. The table found in Figure 2-22 shows the color-mapping algorithm that will be used for this example. Warmer colors (red, orange, yellow) indicate more occurrences. Other intensity-grading schemes can also be used.

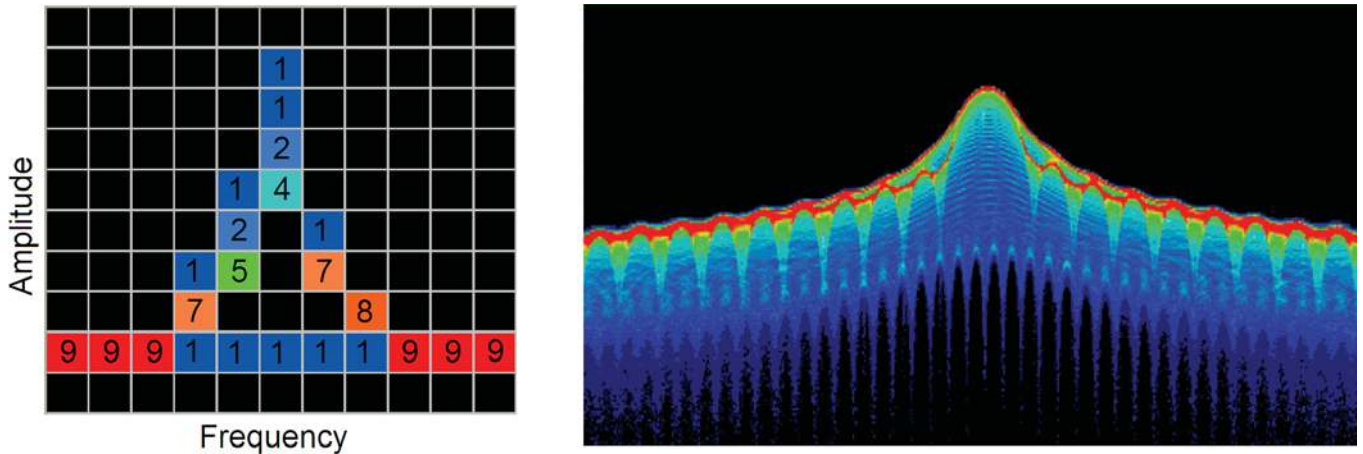

Figure 2-23. Color-coded low-resolution example with Temperature Bitmap (left), and a real DPX display (right) shown with Spectrum Bitmap.

In Figure 2-23, the left image is the result of coloring the database cells according to how many times they were written into by the nine spectrums. Displaying these colored cells, one per pixel on the screen, creates the spectacular DPX displays, as seen in the right image.

Persistence

In the RSA5100 Series, for example, 3 million+ spectrums enter the database each second. At the end of each frame of ~150,000 input spectra (about 20 times per second), the bitmap database is transferred out for additional processing before being displayed, and data from a new frame starts filling the bitmap.

To implement persistence, the DPX engine can keep the existing counts and add to them as new spectrums arrive, rather than clearing the bitmap database counts to zero at the start of each new frame. Maintaining the full count values across frames is “infinite persistence.” If only a fraction of each count is carried over to the next frame, it is called “variable

persistence.” Adjusting the fraction changes the length of time it takes for a signal event to decay from the database, and thus fade from the display.

Imagine a signal that popped up only once during the time DPX was running. Further, assume that it was present for all of the spectrum updates in a frame and that the Variable Persistence Factor causes 25% attenuation after each frame. The cells it affected would start out with a value of 150,000 and be displayed at full force. One frame later, the Number of Occurrences values become 75,000. After the next frame, they are 37,500, then smaller and smaller until they are so dim as to be invisible. On the screen, you would initially see a bright trace with a spike at the signal frequency. The part of the trace where the signal occurred fades away. During this time, the pixels start to brighten at the noise level below the fading signal. In the end, there is only a baseline trace in the display (Figure 2-24, on the next page).

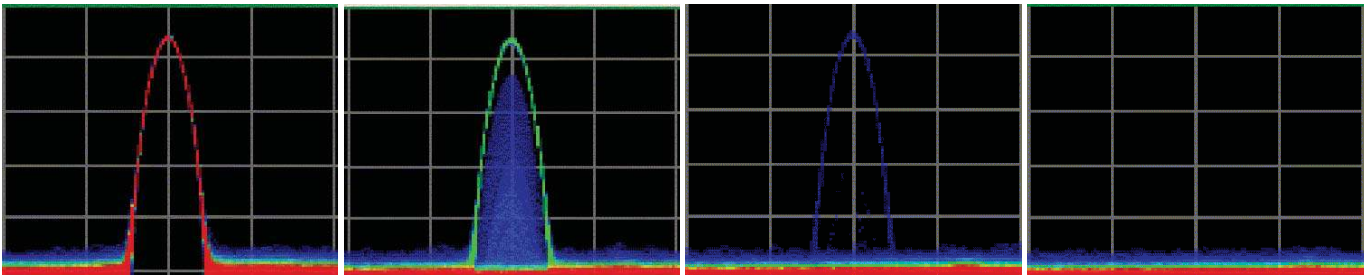

Figure 2-24. With variable persistence, a brief CW signal captured by DPX remains in the display for an adjustable period of time before fading away.

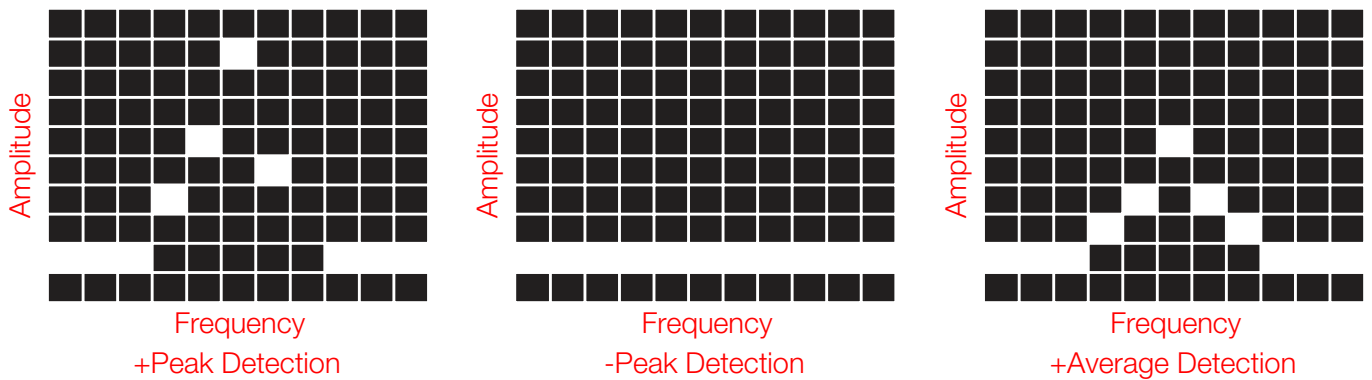

Figure 2-25. Detected traces example: +Peak Detection (left); -Peak Detection (middle); and Average Detection (right).

Persistence is an extremely valuable troubleshooting aid, delivering all the benefits of MaxHold and more. To find out if there is an intermittent signal or occasional shift in frequency or amplitude, you can turn on Infinite Persistence and let the RTSA baby-sit. When you return, you will see not only the highest level for each frequency point, but also the lowest levels and any points in between. Once the presence of transient behavior or intruding signals has been revealed, you can characterize the problem in detail with Variable Persistence.

Statistical Line Traces

A colorful bitmap is DPX Spectrum's signature trace, but DPX also produces statistical line traces. The database contents are queried for the highest, lowest and average amplitude values recorded in each frequency column. The three resulting trace detections are +Peak, -Peak and Average (Figure 2-25).

The +Peak and -Peak traces show signal maxima and minima instantly and clearly. Average detection finds the mean level for the signal at each frequency point. All these traces can be saved and restored for use as reference traces.

Just like regular spectrum traces, DPX line traces can be accumulated over ongoing acquisitions to yield MaxHold, MinHold and Average trace functions. Using Hold on the DPX +Peak trace is almost exactly the same as the MaxHold trace on a typical spectrum analyzer, with the important difference that the DPX trace's update rate is orders of magnitude faster.

The DPX Transform Engine

So how do all those spectrums get generated? In parallel with the software batch processing used for most measurements, and using the same stream of incoming IQ data, there is a hardware-based computation engine devoted to continuous, real-time signal processing. This subsystem supports time-critical functions like power-level triggering, frequency mask triggering and others. It also performs DFTs fast enough to produce the spectrum rate used by the DPX display system.

For more information on DPX display technology, please see Application Note 37W-19638, "DPX Acquisition Technology for Spectrum Analyzers Fundamentals".

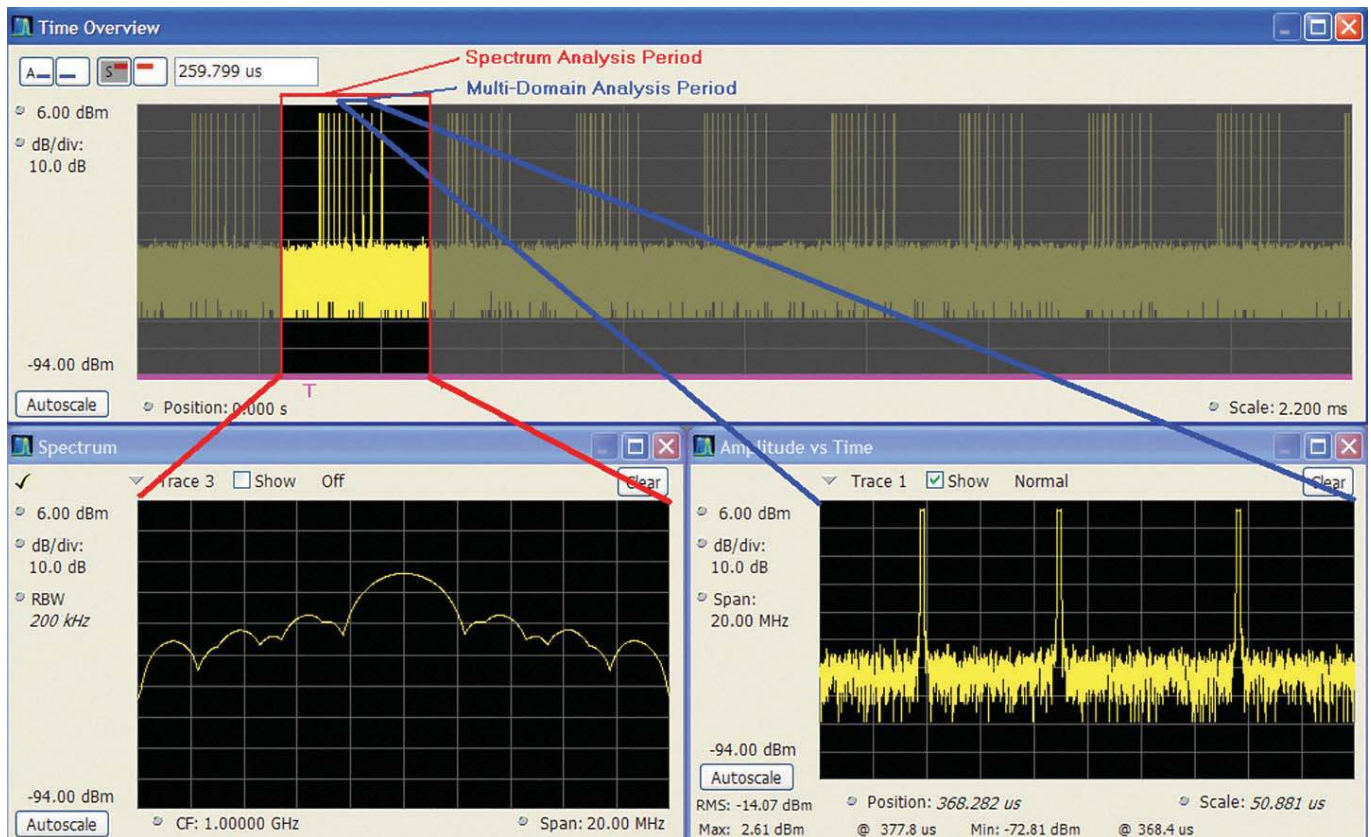

Figure 2-26. Time overview with spectrum length and multi-domain analysis length indicators as shown in the RSA6100.

Timing and Triggers

Real-time processing enables the DPX display that makes the RTSA a powerful discovery tool. However, the DPX display does not keep a time domain record that can re-analyzed in multiple domains. Capture and additional analysis requires that the signal be written into memory, and that the area of interest in the waveform be selected for analysis. This section illustrates the triggering, acquisition and analysis period controls of the RTSA, seen in Figure 2-26.

The timing controls, when used in conjunction with triggers, offer a powerful combination for analyzing transient or other timing related parameters.

The acquisition length specifies the length of time for which samples will be stored in memory in response to a trigger. The acquisition history determines how many previous acquisitions will be kept after each new trigger. Tektronix RTSAs show the entire acquisition length in the time domain overview window.

The spectrum length determines the length of time for which spectrum displays are calculated. The spectrum offset determines the delay or advance from the instant of the trigger event until the beginning of the FFT frame that is displayed. Both spectrum length and spectrum offset have a time resolution of one FFT frame. Tektronix high performance RTSAs allow one to vary the FFT length for spectrum viewing. They indicate the spectrum offset and spectrum length using a colored bar at the bottom of the time domain overview window. The bar color is keyed to the pertinent display.

The analysis length determines the length of time for which modulation analysis and other time-based measurements are made. The analysis offset determines the delay or advance from the instant of the trigger until the beginning of the analysis. Tektronix RTSAs indicate the analysis offset and length using a colored bar at the bottom of the time domain overview window. The bar color is keyed to the pertinent display.

The output trigger indicator allows the user to selectively enable a TTL rear-panel output at the instant of a trigger. This can be used to synchronize RTSA measurements with other instruments such as oscilloscopes or logic analyzers.

Real-Time Triggering and Acquisition

The RTSA is capable of performing time, spectrum, and modulation analysis. Triggering is critical to capturing time domain information. The RTSA offers unique trigger functionality, providing frequency-edge, density, and FMTs (Frequency Mask Triggers) as well as the usual power, external and level-based triggers.

The most common trigger system is the one used in most oscilloscopes. In traditional analog oscilloscopes, the signal to be observed is fed to one input while the trigger is fed to another. The trigger event causes the start of a horizontal sweep while the amplitude of the signal is shown as a vertical displacement superimposed on a calibrated graticule. In its simplest form, analog triggering allows events that happen after the trigger to be observed, as shown in Figure 2-27.

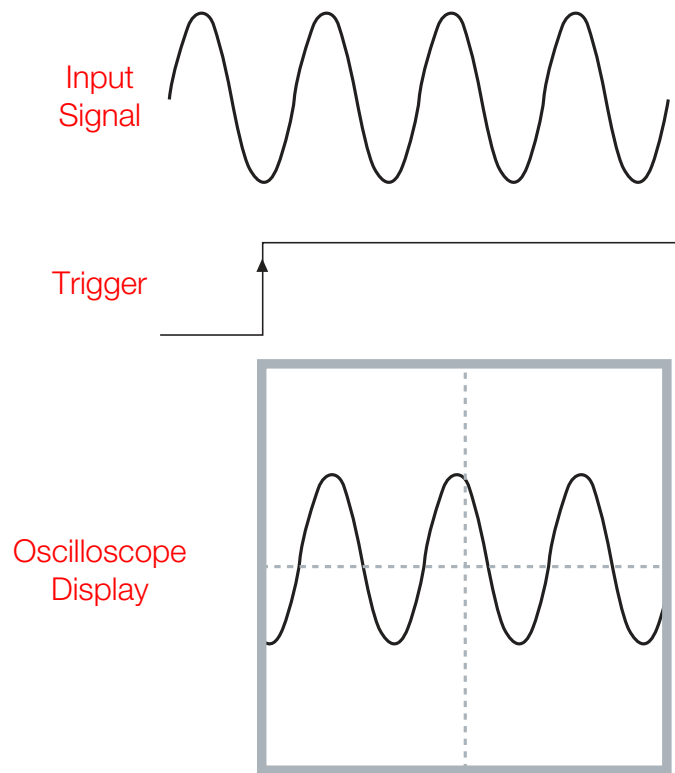

Figure 2-27. Traditional oscilloscope triggering.

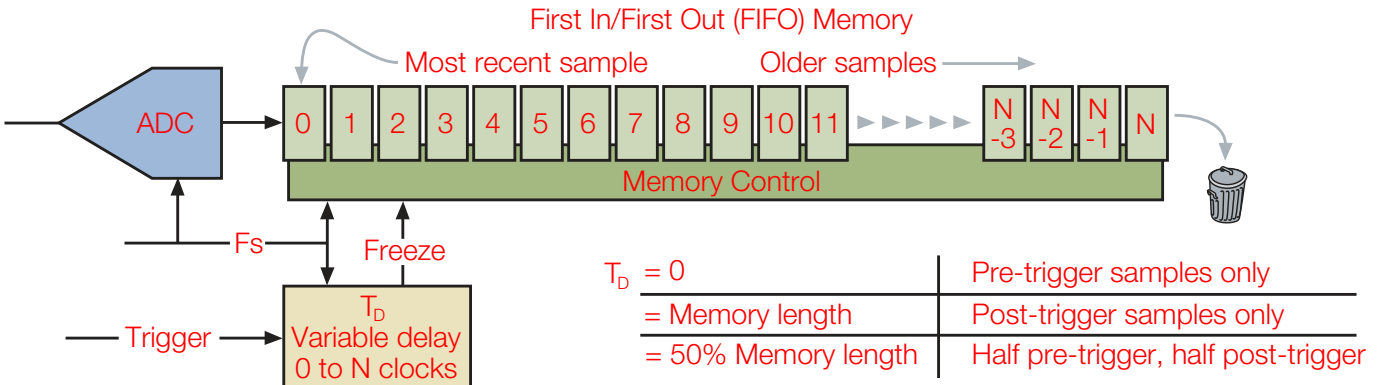

Figure 2-28. Triggering in digital acquisition systems.

Triggering in Systems with Digital Acquisition

The ability to represent and process signals digitally, coupled with large memory capacity, allows the capture of events that happen before the trigger as well as after it.

Digital acquisition systems of the type used in Tektronix RTSAs use an Analog-to-Digital Converter (ADC) to fill a deep memory with time samples of the received signal. Conceptually, new samples are continuously fed to the memory while the oldest samples fall off. The example shown in Figure 2-28 shows a memory configured to store “N” samples. The arrival of a trigger stops the acquisition, freezing the contents of the memory. The addition of a variable delay in the path of the trigger signal allows events that happen before a trigger as well as those that come after it to be captured.

Consider a case in which there is no delay. The trigger event causes the memory to freeze immediately after a sample concurrent with the trigger is stored. The memory then contains the sample at the time of the trigger as well as “N” samples that occurred before the trigger. Only pre-trigger events are stored.

Consider now the case in which the delay is set to match exactly the length of the memory. “N” samples are then allowed to come into the memory after the trigger occurrence before the memory is frozen. The memory then contains “N” samples of signal activity after the trigger. Only post-trigger events are stored.

Both post- and pre-trigger events can be captured if the delay is set to a fraction of the memory length. If the delay is set to half of the memory depth, half of the stored samples are those that preceded the trigger and half the stored samples followed it. This concept is similar to a trigger delay used in zero span mode of a conventional SA. The RTSA can capture much longer time records, however, and this signal data can subsequently be analyzed in the frequency, time, and modulation domains. This is a powerful tool for applications such as signal monitoring and device troubleshooting.

Trigger Modes and Features

The free-run mode acquires samples of the received IF signal without the consideration of any trigger conditions. Spectrum, modulation or other measurements are displayed as they are acquired and processed.

The triggered mode requires a trigger source as well as the setting of various parameters that define the conditions for triggering as well as the instrument behavior in response to a trigger.

A selection of continuous or single trigger determines whether acquisitions repeat each time a trigger occurs or are taken only once each time a measurement is armed. The trigger position, adjustable from 0 to 100%, selects which portion of an acquisition block is pre-trigger. A selection of 10% captures pre-trigger data for one tenth of the selected block and post-trigger data for nine tenths. Trigger slope allows the selection of rising edges, falling edges or their combination for triggering. Rise and fall allows the capture of complete bursts. Fall and rise allows the capture of gaps in an otherwise continuous signal.

Trigger Source	Trigger Signal	Setting Units	Uncertainty	Notes
External	External trigger connector	Volts (variable) or TTL	RSA306: ± 250 ns RSA5100: ± 4 ns RSA6100: ± 5 ns	RSA306: 1 ext. trig Input RSA5100/6100: 2 ext. trig Inputs (front and rear)
Power Level Trigger	Power calculated within current acquisition BW	Power, or dB relative to full scale	± 1 time domain points (based on effective sampling rate)	RSA5100/6100 add user-settable filter bandwidth to trigger
Frequency Mask Trigger	Point-by-point comparison at the output of FFT processor	dB and Hz, based on the graphical mask drawn on screen	RSA306: N/A RSA5100/6100: ± 1 frame length	Frame length based on effective sampling rate
DPX Density Trigger	Point-by-point comparison of DPX data	% threshold, based on Δ frequency & Δ amplitude	RSA306: N/A RSA5100/6100: ± 1 frame length	Frame length based on effective sampling rate
Frequency Edge Trigger	Frequency comparison at the output of FFT processor	Hz	RSA306: N/A RSA5100/6100: ± 1 time domain points	RSA5100/6100 add user-settable filter bandwidth to trigger

Table 2-1. Comparison of Real-Time Spectrum Analyzers trigger sources.

Real-Time Spectrum Analyzer Trigger Sources

Tektronix RTSAs provide several methods of internal and external triggering. Table 2-1 summarizes the various real-time trigger sources, their settings, and the time resolution that is associated with each one.

External triggering allows an external signal to control the acquisition. This is typically a control signal such as a frequency switching command from the system under test. This external signal prompts the acquisition of an event in the system under test.

Internal triggering depends on the characteristics of the signal being tested. The various RTSA models have the ability to trigger on the level of the digitized signal, on the power of the signal after filtering and decimation, or on the occurrence of specific spectral components using the FMT (note: the RSA306 does not support frequency mask triggering). Each of the trigger sources and modes offers specific advantages in terms of frequency selectivity, time resolution and dynamic range. The functional elements that support these features are shown in Figure 2-29 (on the next page).

Level triggering compares the digitized signal at the output of the ADC with a user-selected setting. The full bandwidth

of the digitized signal is used, even when observing narrow spans that require further filtering and decimation. Level triggering uses the full digitization rate and can detect events with durations as brief as one sample at the full sampling rate. The time resolution of the downstream analysis, however, is limited to the decimated effective sampling rate. Level trigger is available on some RTSA models.

Power triggering calculates the power of the signal after filtering and decimation. The power of each filtered pair of IQ samples (I^2+Q^2) is compared with a user-selected power setting. Some RTSA models offer a filtered power trigger where a filter with a selectable bandwidth to be applied to the signal in the trigger path.

Frequency-edge triggering looks at the change in frequency as a function of time, and triggers on a specified change in level. Triggering can be done on rising or falling frequencies, similar to the way a time domain level trigger works.

Triggering can also be done on DPX density. Since the DPX histogram is a 2D array in frequency and amplitude, a box with specified upper and lower frequencies and upper and lower amplitudes can be defined. When the data density in the specified box reaches a specified threshold, a trigger is created.

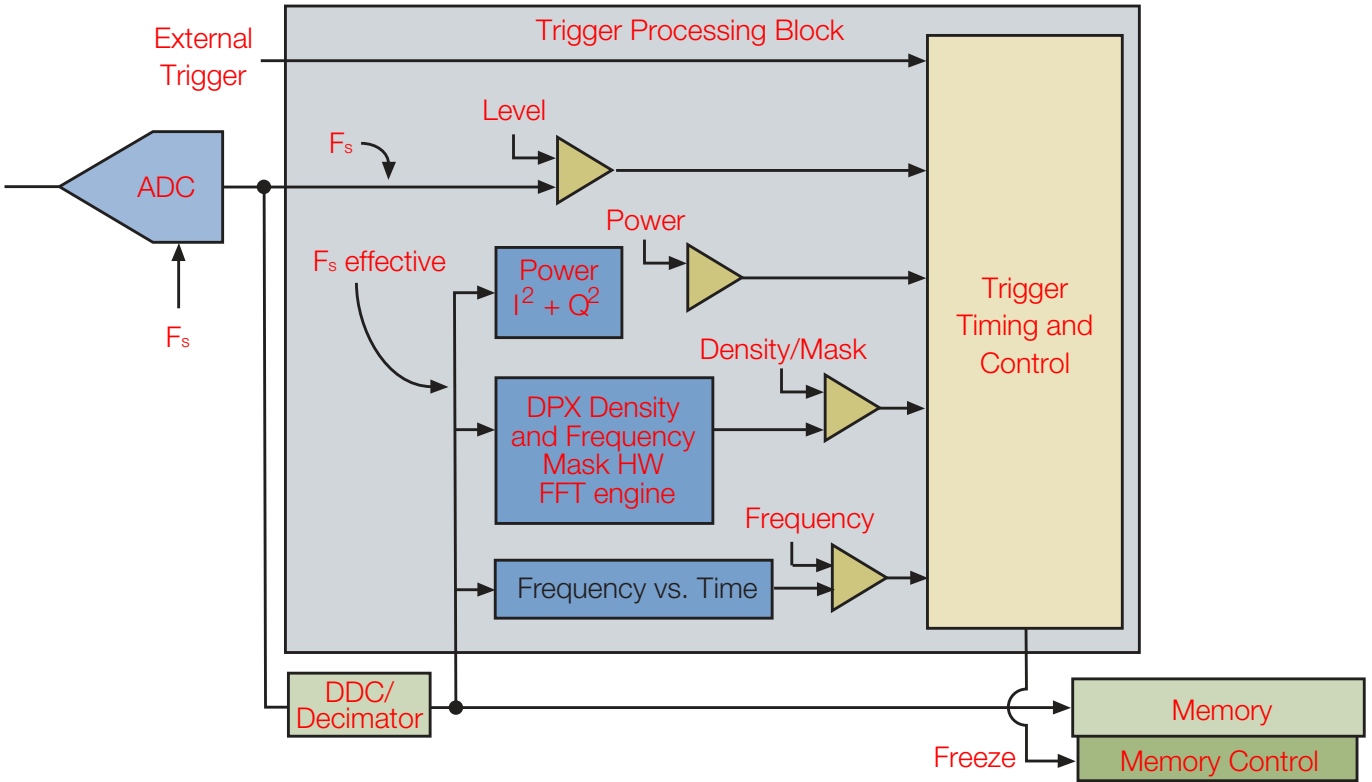

Figure 2-29. Real-Time Spectrum Analyzer trigger processing.

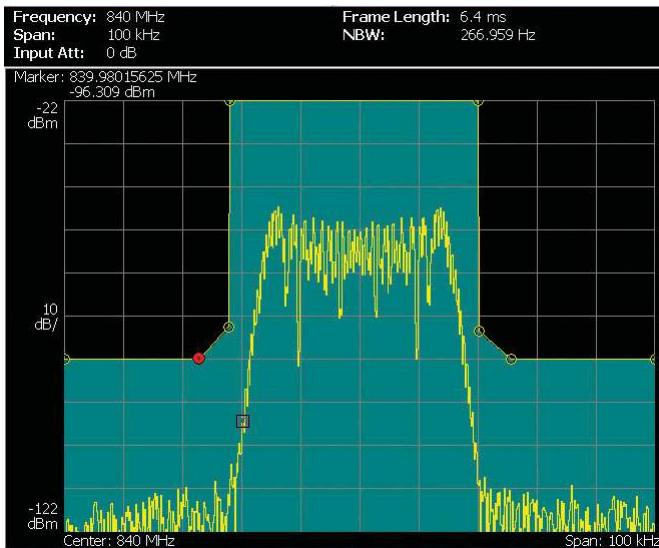

Figure 2-30. Frequency mask definition.

Frequency mask triggering compares the spectrum shape to a user-defined mask. This powerful technique allows changes in a spectrum shape to trigger an acquisition. FMTs can reliably detect signals far below full-scale even in the presence of other signals at much higher levels. This ability to trigger on weak signals in the presence of strong ones is critical for

detecting intermittent signals, the presence of inter-modulation products, transient spectrum containment violations, and much more. A full DFT is required to compare a signal to a mask, requiring a complete frame. The time resolution for FMT is roughly one DFT frame. Trigger events are determined in the frequency domain using a dedicated hardware DFT processor, as shown in the block diagram in Figure 2-29.

Constructing a Frequency Mask

Like other forms of mask testing, the FMT (also known as frequency domain trigger) starts with a definition of an on-screen mask. This definition is done with a set of frequency points and their amplitudes. The mask can be defined point-by-point or graphically by drawing it with a mouse or other pointing device. Triggers can be set to occur when a signal outside the mask boundary “breaks in,” or when a signal inside the mask boundary “breaks out.”

Figure 2-30 shows a frequency mask defined to allow the passage of the normal spectrum of a signal but not momentary aberrations. On the next page, Figure 2-31 shows a spectrogram display for an acquisition that was triggered when the signal momentarily exceeded the mask. Figure 2-32 shows the spectrum for the first frame where the mask was exceeded. Note that pre-trigger and post-trigger data were collected and are both shown in the spectrogram.

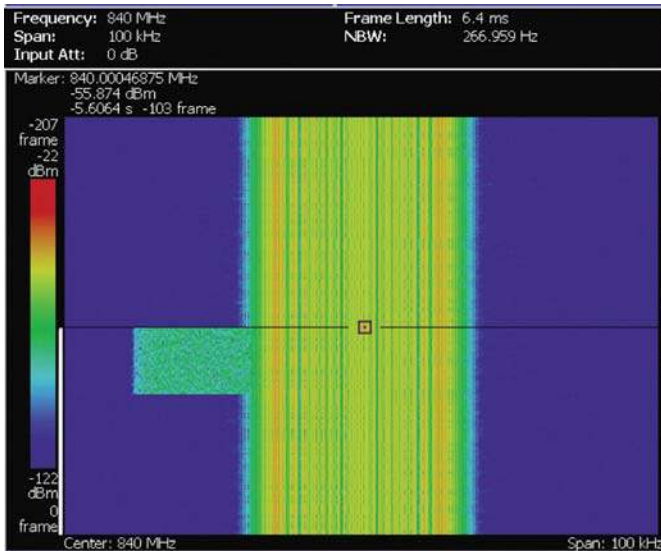

Figure 2-31. Spectrogram showing a transient signal adjacent to the carrier. The cursor is set to the trigger point, so pre-trigger data is displayed above the cursor line, and post-trigger data is displayed below the cursor line. The narrow white line at the left of the blue area denotes post-trigger data.

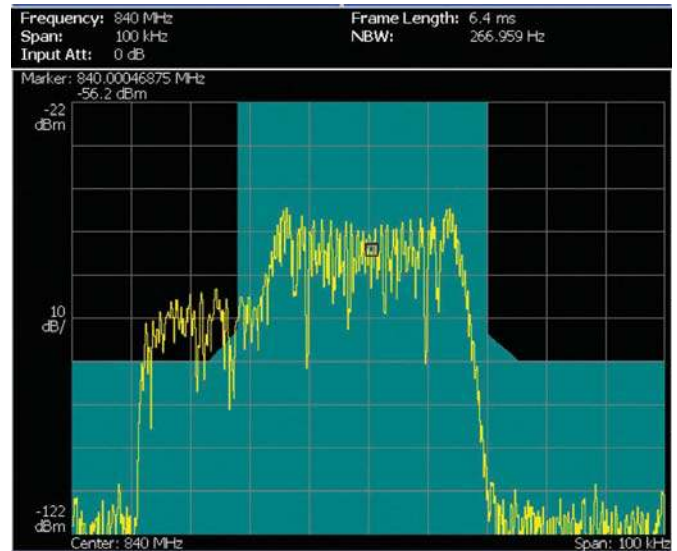

Figure 2-32. One frame of the spectrogram showing the trigger event where the transient signal breaks the boundary of the frequency mask.

Modulation Analysis

Modulation is the means through which RF signals carry information. Modulation analysis using the Tektronix RTSA not only extracts the data being transmitted but also measures the accuracy with which signals are modulated. Moreover, it quantifies many of the errors and impairments that degrade modulation quality.

Modern communications systems have dramatically increased the number of modulation formats in use. The RTSA is capable of analyzing the most common formats and has an architecture that allows for the analysis of new formats as they emerge.

Amplitude, Frequency, and Phase Modulation

RF carriers can transport information in many ways based on variations in the amplitude or phase of the carrier. Frequency

is the time derivative of phase. Frequency Modulation (FM) is therefore the time derivative of Phase Modulation (PM). Quadrature Phase Shift Keying (QPSK) is a digital modulation format in which the symbol decision points occur at multiples of 90 degrees of phase. Quadrature Amplitude Modulation (QAM) is a high-order modulation format in which both amplitude and phase are varied simultaneously to provide multiple states. Even highly complex modulation formats such as Orthogonal Frequency Division Multiplexing (OFDM) can be decomposed into magnitude and phase components.

Magnitude and phase can be thought of as the length and the angle of a vector in a polar coordinate system. The same point can be expressed in Cartesian (or rectangular) coordinates (X,Y). The IQ format of the time samples stored in memory by the RTSA are mathematically equivalent to Cartesian coordinates with I representing the horizontal or X component and Q the vertical or Y component.

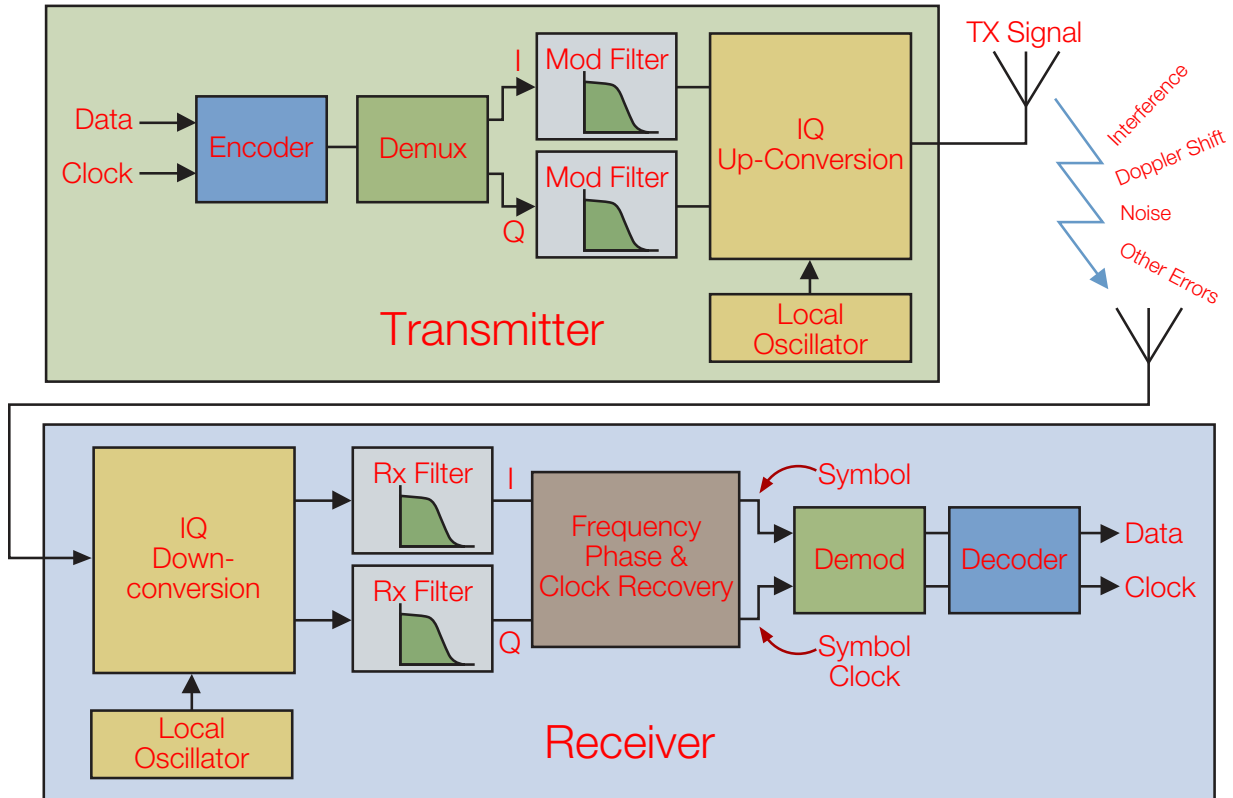

Figure 2-34. Typical digital communications system.

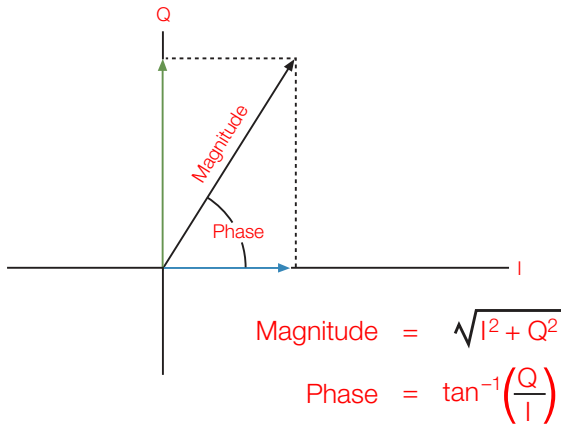

Figure 2-33. Vector representation of magnitude and phase.

Figure 2-33 illustrates the magnitude and phase of a vector along with its I and Q components. AM demodulation consists of computing the instantaneous magnitude for each IQ sample and plotting the result over time. PM demodulation consists of computing the phase angle of the IQ samples and plotting them over time after accounting for the discontinuities of the arctangent function at $\pm\pi/2$. FM is computed using the property that frequency is the time-derivative of phase.

Digital Modulation

Figure 2-34 shows the signal processing in a typical digital communications system. The transmit process starts with the data to be sent and a clock. The data and clock are passed through an encoder that re-arranges the data, adds synchronization bits, and does encoding and scrambling which might be used in the receiver to recover errors that inevitably occur when signals are transmitted over the air. The data is then split into I and Q paths and filtered, upconverted to the appropriate channel and transmitted over the air.

The process of reception is the reverse of transmission with some additional steps. The RF signal is downconverted to I and Q baseband signals which are passed through Rx filters often designed to remove inter-symbol interference. The signal is then passed through an algorithm that recovers the exact frequency, phase and data clock. This is necessary to correct for multi-path delay and Doppler shift in the path and for the fact that the Rx and Tx local oscillators are not usually synchronized. Once frequency, phase and clock are recovered, the signal is demodulated and decoded, errors are corrected, and bits lost due to signal degradation in the transmission path are recovered.

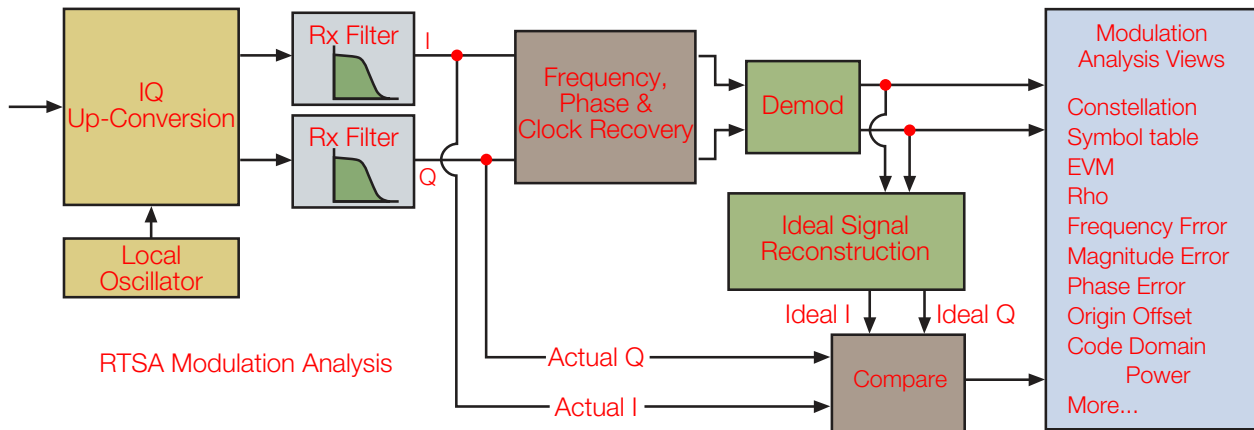

Figure 2-35. RTSA modulation analysis block diagram.

The varieties of digital modulation are numerous and include the familiar FSK, BPSK, QPSK, GMSK, QAM, OFDM and others. Digital modulation is often combined with channel assignments, filtering, power control, error correction and communications protocols to encompass a particular digital communication standard whose purpose is to transmit error-free bits of information between radios at opposite ends of a link. Much of the complexity incurred in a digital communication format is necessary to compensate for the errors and impairments that enter the system as the signal travels over the air or other media.

Figure 2-35 illustrates the signal processing steps required for a digital modulation analysis. The basic process is the same as that of a receiver except that modulation accuracy measurements require a comparison between the received and ideal modulation waveforms. The method used in most RTSA modulation quality measurements is to use the recovered symbols to reconstruct the mathematically ideal I and Q signals. These ideal signals are compared with the actual or degraded I and Q signals to generate the required modulation analysis views and measurements.

Power Measurements and Statistics

Tektronix RTSAs can perform power measurements both in the frequency domain and in the time domain. Time domain measurements are made by integrating the power in the I and Q baseband signals stored in memory over a specified time interval. Frequency domain measurements are made by integrating the power in the spectrum over a specified frequency interval. Channel filters, required for many standards-based measurements, may be applied to yield the resultant channel power. Calibration and normalization parameters are also applied to maintain accuracy under all specified conditions.

Communications standards often specify statistical measurements for components and end-user devices. RTSAs have measurement routines to calculate statistics such as the Complementary Cumulative Distribution Function (CCDF) of a signal which is often used to characterize the statistics including the Peak-Average Ratio (PAR) behavior of complex modulated signals.



Figure 3-1. Spectrogram display, showing a waterfall plot of spectra as a function of time for an OFDM signal, compared to a DPX spectrogram in the bottom frame.

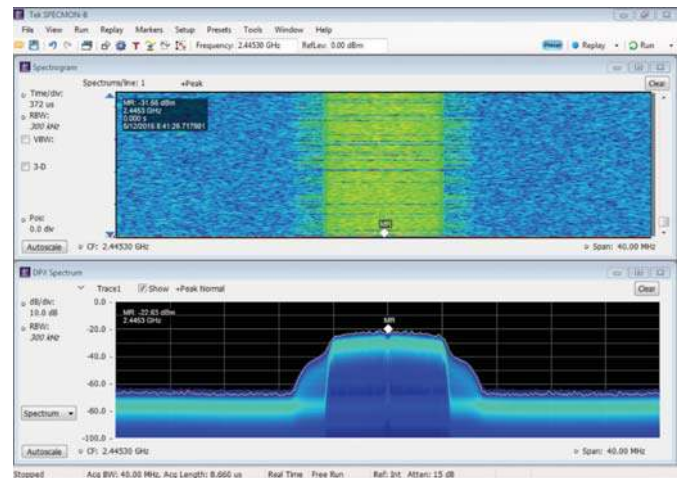

Figure 3-2. Color-graded spectrogram of an OFDM RF signal from a Tektronix RSA-5126B Real-Time Spectrum Analyzer.

Chapter 3: Correlation Between Time and Frequency Domain Measurements

Spectrum analyzers are primarily frequency domain instruments, but there are many measurements where it is useful either to observe spectral features in the time domain, or to control where spectral measurements are made as a function of time. The Real Time Spectrum Analyzer has an advantage in locating events precisely in both the time and frequency domain because of the nature of its operation: it acquires measurements in the time domain and converts that information to the frequency domain using the discrete Fourier transform.

Typical ways to display frequency domain information include the RF spectrum, the DPX spectral information display, and the spectrogram. As described previously, the RF spectrum can be obtained by sweeping a reference oscillator and recording the mixed-down amplitude as a function of time (swept spectrum analysis). The RF spectrum can also be recorded by allowing a broad range of frequencies to pass through filters, downconverting the signal with a fixed reference oscillator, digitizing data using a high resolution ADC, and converting the time domain

sequence to a spectrum using an efficient implementation of the discrete Fourier transform (real-time spectrum analysis). Since the Fourier transform can be obtained very quickly using an algorithm such as the FFT (Fast Fourier Transform) implemented in a parallel fashion in FPGA hardware, or in software in a fast modern processor, the spectrum can be displayed more quickly than an oscillator can be swept in traditional swept spectrum analysis. In addition, since the time domain information is available to the system from the ADC output, it is quite easy to correlate the appearance of a particular spectral feature with the time the data were acquired.

Spectrograms

The most useful display in this regard is the spectrogram, which displays complete spectra as a function of time and lets the user see a continuously updated history of events. Common ways of displaying this information are a waterfall plot (pseudo-3D plot where spectra are offset), and a color-coded representation of spectra where the amplitude is represented by graded colors. An example of a 3D waterfall display is shown in Figure 3-1. An example of a color-graded spectrogram is shown in Figure 3-2, where the signal is an OFDM RF transmission.

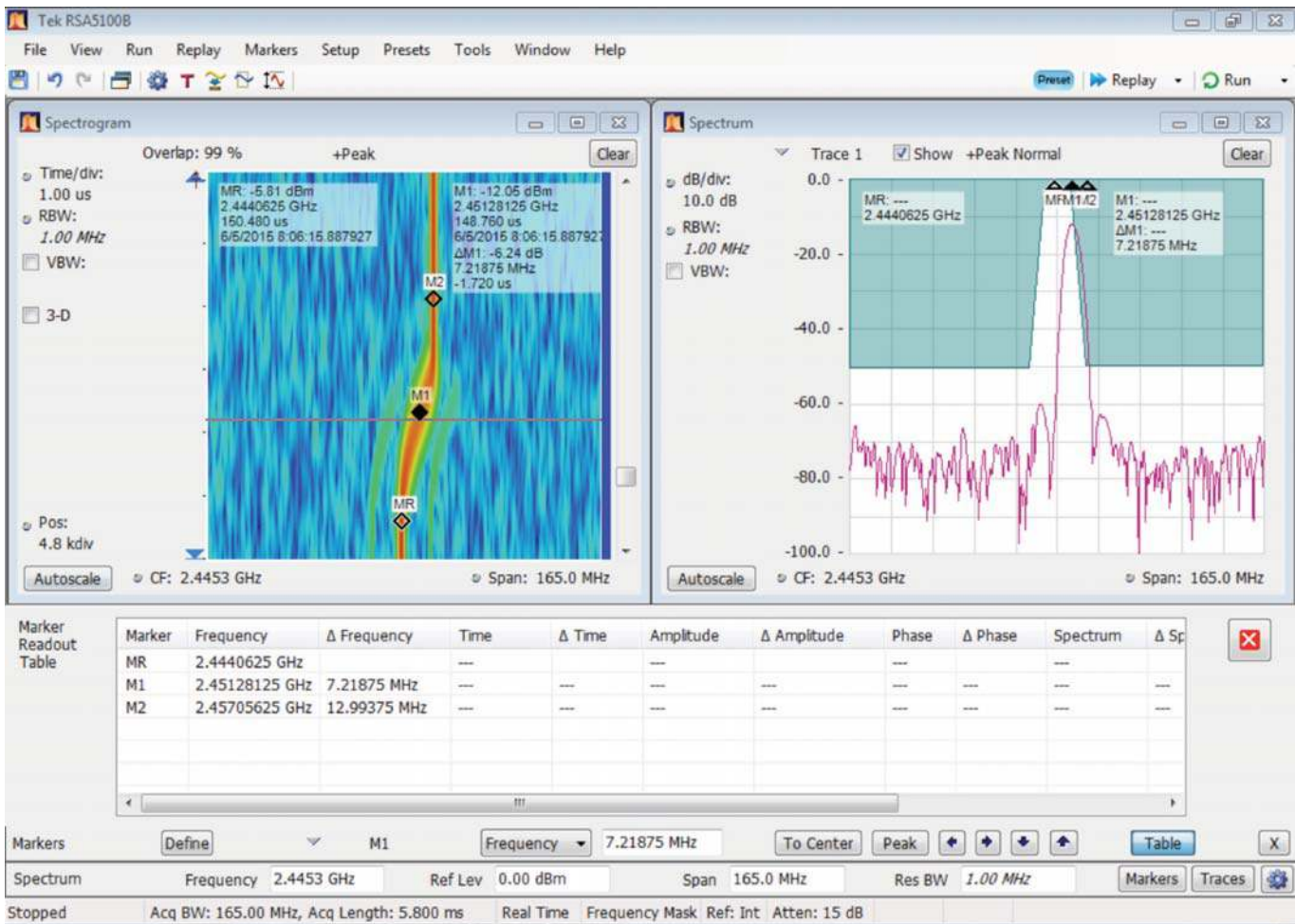

Figure 3-3. Frequency hopping signal showing the frequency change in a spectrogram with 20 ns time resolution due to DFT overlap. Note that overlap is reported as 99%; in this case each DFT is shifted by 4 I-Q samples.

The time resolution of the spectrogram is determined by two factors: 1) the sampling rate of the ADC, and 2) the length of the DFT used to produce the spectrum. The length of the DFT determines the frequency resolution obtained, so we would like to keep it reasonably long. A typical sampling rate for a real-time spectrum analyzer is 400 Msamples/sec (or 200 M I-Q data points/sec). For a relatively short DFT of 256 points, a complete spectrum can be acquired in 1.28 usec. Since DFTs can be overlapped in time, however, with multiple spectra being calculated with some of the same data simultaneously, the timing resolution for frequency domain events can be improved by the overlap factor. For an overlap of 75% in this example, the timing resolution for our short capture can be improved to 320 nsec. If we overlap the DFTs in one sample increments, the timing resolution for spectra improves to 5 nsec. In our example above with a 400 MS/s ADC and a 256-point DFT, the minimum frequency separation that could be examined would be about 780 kHz.

Tektronix RTSAs can perform DFT calculations with arbitrary sample overlap on contiguous data acquired into memory. With a long record length captured by triggering an acquisition into sample memory of a hopping signal, for example, spectra with good frequency resolution and very short time resolution can be calculated, as shown in the example above. It is possible to scan through the spectrogram data at coarse or fine time resolution, and display the individual spectra in a spectrum window. Shown in Figure 3-3 are a spectrogram expanded to have 20 ns time separation between spectra, and the spectrum associated with the marker displayed in the spectrum window. More information about DFT overlap processing can be found in the Tektronix publication “Understanding FFT Overlap Processing Fundamentals” (Publication 37W-18839-1).

Swept FFT Analysis

When the bandwidth to be examined exceeds the real-time bandwidth of the spectrum analyzer (165 MHz in the above example using a 400 MS/s ADC), multiple real-time spectra can be stitched together to provide additional spectral coverage. While this reduces the speed at which changes in spectral features can be discovered, the technique still provides a substantial improvement in measurement time over swept spectrum analyzers for narrow resolution bandwidths. For broad spectral coverage in a real-time spectrum analyzer, the first part of a the spectrum is recorded by setting the acquisition frequency to the center of the first block of frequencies to be acquired, then stepping the reference oscillator to the center of the next block of frequencies and performing a second acquisition, and repeating until the desired spectrum is complete. The amount of time taken to assemble the full spectrum depends on the RBW (resolution bandwidth) selected which determines the FFT length, and whether averaging is used to reduce noise.

In addition to single spectra, the swept FFT approach described above can also be applied to DPX analysis. For DPX analysis as you will recall, all spectral data is histogrammed in real time such that no information is lost. When the DPX technique is extended to wide spectra beyond the real-time bandwidth, though, the reference oscillator must be tuned to new frequencies during the spectrum and thus some information is by definition missed during the scan.

For constant or repetitive signals this will not be a problem, but the swept DPX display will be blind to signals that occur when it not processing a portion of the sweep where an event occurs. One way to mitigate this is with the dwell setting in the DPX swept display. Dwell sets the length of time for each step in a stepped sweep, and can be set from 50 ms to 100 s. During the dwell time, probability of intercept in the step is the same as if the instrument were working in a real-time bandwidth, but the unit is blind to the other steps in the sweep during this time. So, if you have a sweep that requires 5 steps, you could dwell on each step for a time required to get a complete look at spectral activity, then move on to the next step. In principle true DPX analysis could be extended to wider frequency ranges by either extending the sampling rate of the ADC to much higher frequency, or by implementing parallel ADCs and filter paths that simultaneously capture multiple blocks of spectrum. In practice the ultra-wideband digitizer approach has drawbacks both in implementing very wideband filters and in higher noise in this type of ADC. The parallel approach is impractical in a single instrument because it requires substantial duplication of hardware in the instrument and complex display issues. A possible approach could be to synchronize multiple RTSAs tuned to different frequencies to cover all bands of interest. However, the phase relationships between the multiple RTSAs local oscillators is different, so vector measurements would not be possible. But, this approach would allow no gaps when looking between bands for infrequently occurring events in the frequency domain.

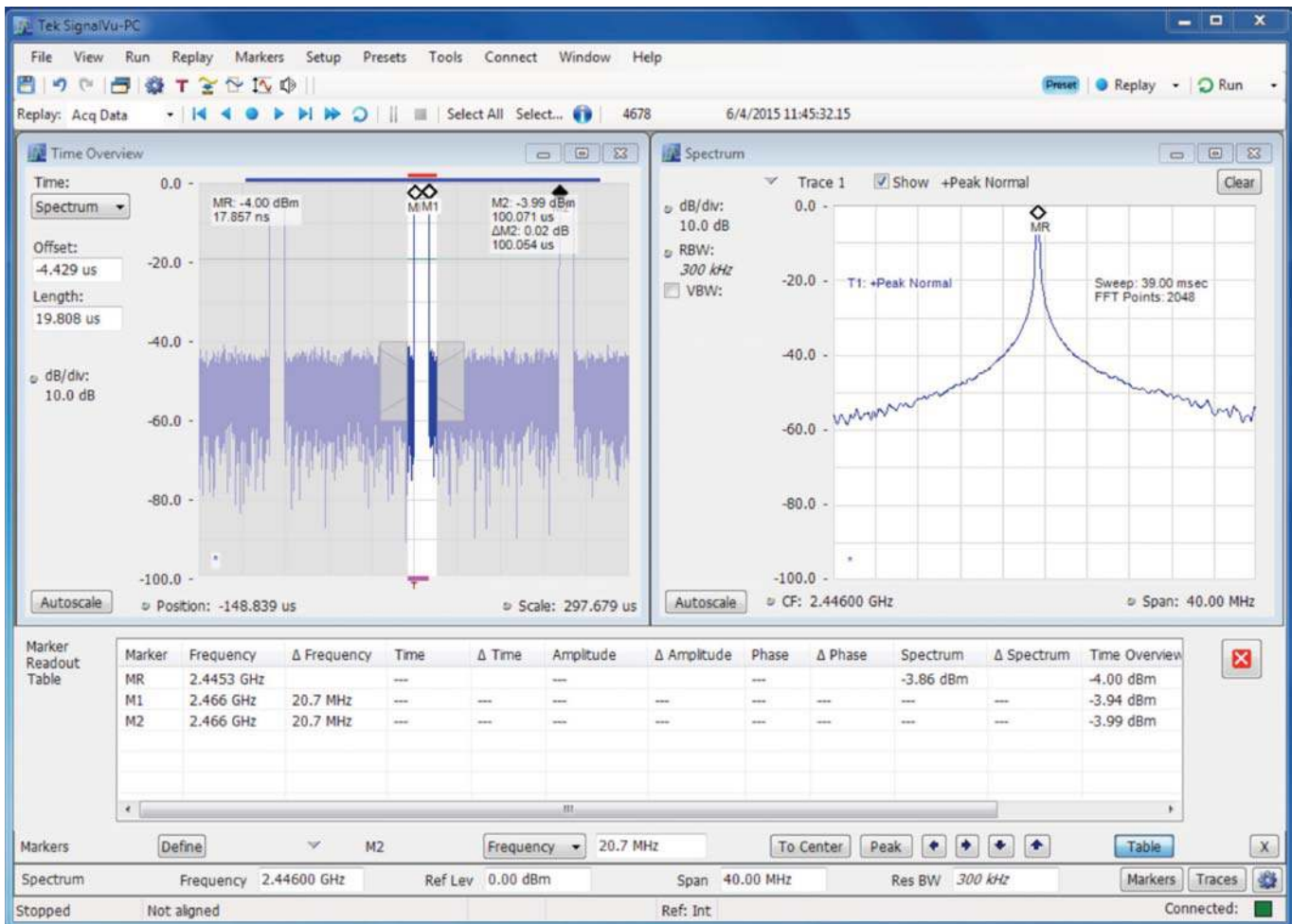

Figure 3-4. Time overview and spectrum of a CW modulated pulse at 2.445 GHz.

Time control of acquisition and analysis

Since in a real-time spectrum analyzer time domain information is always collected, it can be used both to change settings on the instrument that control when data is collected and how it is analyzed. The primary control over when data is acquired are the various trigger functions described in Chapter 2. The frequency mask triggers available in DPX are particularly valuable when trying to analyze an infrequent signal that has a unique frequency signature that can be identified in the presence of other signals. In some instances, however, it is the amplitude vs. time information that is more important in identifying signals of interest. Hopping signals are one example of this type.

Tektronix real-time spectrum analyzers use a window titled "Time Overview" for control of acquisition and analysis timing. Figure 3-4 shows an example of a stream of pulses modulated by a 2.445277 GHz carrier. The time overview

window can be used to view the pulse train, and make modifications to how many pulses are acquired by using the acquisition settings to adjust the acquisition length by either the number of samples or the amount of time. The overview window also shows which portion of the captured signal is used for analysis in the frequency domain. The gray "curtains" can be moved back and forth and used to determine which samples are part of the DFT analysis (also shown by the red bar at the top of the window). In this case the analysis is done on a single pulse and includes some of the "off" time. The window can be modified to include multiple pulses or to be limited to just part of the "on" time of the pulses depending on the type of modulation and the desired analysis. Note that the spectrum time (indicated by the red bar in the Time Overview window) must be long enough to contain at least one DFT; if the spectrum time is set too low to realize the RBW, the user will get a warning message.

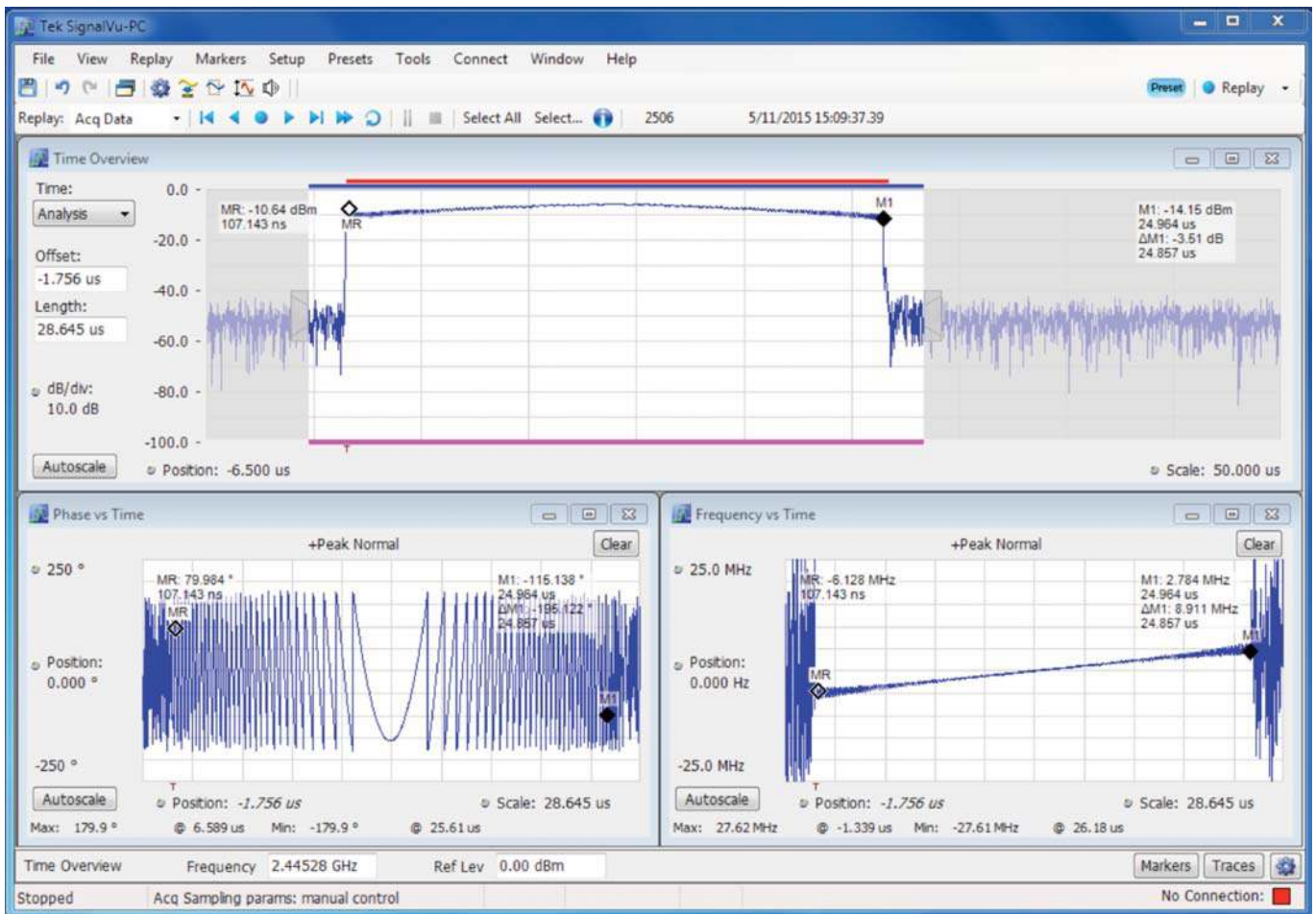

Figure 3-5. LFM modulated pulse showing phase and frequency as a function of time.

Time Domain Measurements

There are many types of measurements made on RF signals that include time as a parameter. Some of the measurements that are included in the Tektronix spectrum analyzer software are the following:

- Frequency vs. time
- Amplitude or power vs. time
- I and Q vs. time
- Phase vs. time
- Modulation parameters vs. time (frequency deviation, phase error, magnitude error, error vector magnitude)
- Frequency settling
- Phase settling

Examination of frequency measurements over time can be very useful for diagnosing issues with transmitters. Modulation typically varies parameters like frequency, amplitude, or phase over time, and examining time plots of these can show how

the system is behaving. Shown in Figure 3-5 is an analysis of a 25 usec pulse where frequency is varying linearly as a function of time. In this case, the analysis time is indicated in the time overview by the blue bar at the top of the display, and the red bar indicates the analysis length for spectrum analysis.

Pulse Measurements

Perhaps the most useful correlation between the time and frequency domains is in the area of pulse measurements. Tektronix Real-Time Spectrum Analyzers (RTSAs) are ideally suited for making pulse measurements. Automatic pulse measurement software can be included on all models of RTSA. Extensive analysis on individual and pulse trend information can be selected. Unlike traditional spectrum analyzers, the various models of RTSA are specified for system risetime/falltime (to 10 ns), minimum pulse duration (as short as 50 ns), and modulation bandwidths to 165 MHz. For faster risetimes, pulses, and wider modulation bandwidths, the SignalVu-PC software can be used in conjunction with Tektronix DPO70000 Series oscilloscopes for automatic pulse measurements in the picoseconds and bandwidths up to 70 GHz.

Individual pulse information for carrier frequency, risetime, falltime, droop, ripple, occupied spectrum, and pulsewidth are among the many pulse measurements that can be selected and characterized on the pulse measurement analysis software.

Pulse trend statistics information includes PRF, duty cycle, and pulse-to-pulse phase information. In addition, statistical information can be displayed as a trend, or Fast Fourier Transforms (FFTs) can be performed over the sampled data to reveal important diagnostic information.

Chapter 4: Real-Time Spectrum Analyzer Applications

This chapter describes some of the application areas that real-time spectrum analyzers are useful in testing. For each application area the pertinent measurement types are discussed, and advantages of real-time analyzers are highlighted. Before we get started, however, it is worth discussing some of the different types of real-time spectrum analyzers, since their characteristics will have a bearing on how they are used in different application areas.

Real-Time Analyzers: Laboratory to Field

Much of the discussion so far has been general to any type of real-time spectrum analyzer. Benchtop laboratory analyzers have been pushing the state of the art for more than 2 decades now, with each version improving both real-time bandwidth with faster digitizers, and RF performance with improved mixers, amplifiers, filters, and shielding. The spur-free dynamic range of benchtop real-time spectrum analyzers, controlled by spurious peaks generated by nonlinear elements in the signal chain, now exceeds 80 dBc.

A new generation of hand-held real-time spectrum analyzers is now appearing, however, which trade off some of the RF performance achievable in benchtop analyzers for low power and portability. The primary trade-off is with power; benchtop analyzers typically use > 300 W of power for very linear RF components and hardware digital signal processing that

	RSA306	RSA5126B
Frequency range	9 kHz - 6.2 GHz	1 Hz - 26.5 GHz
Real-time analysis bandwidth	40 MHz	25 MHz - 165 MHz
IQ sample rate	56 MS/s	200 MS/s
100% POI pulse duration	100 μ s	0.43 μ s
Amplitude accuracy (95% confidence to 3 GHz)	+/- 1.25 dB	+/-0.3 dB
Resolution BW range	1 Hz - 8 MHz	0.1 Hz - 20 MHz
Max CW measurement input power	+20 dBm	+30 dBm
DANL (1 GHz with preamp)	-163 dBm/Hz	-167 dBm/Hz
SSB phase noise (10 kHz)	-84 dBc/Hz	-109 dBc/Hz
Spur-free dynamic range	> 50 dBc	> 80 dBc
Residual spurious (-50 dBm ref)	< -78 dBm	< -95 dBm
Power	< 4.5 W	< 400 W

Table 4-1. Comparison of USB and Benchtop Real-Time Spectrum Analyzers.

allows for fast FFTs and advanced triggering, while hand-held analyzers typically use < 5 W of power. The developments that make such low power analyzers possible are twofold: 1) commodity low power RF components have been developed for cell phone use, and 2) low power microprocessors with very fast processing speeds have been developed for cell phones, tablets, and laptop computers where battery longevity is extremely important. Handheld real-time spectrum analyzers depend on fast software processing to convert time domain ADC samples to frequency spectra and do data decimation and filtering. As processors and algorithms improve, these instruments will also improve.

Shown in Table 4-1 is a comparison of a Tektronix USB-connected spectrum analyzer with a mid-range benchtop real-time spectrum analyzer. In the applications and examples to follow, the suitability of both types of analyzers for the applications will be described.

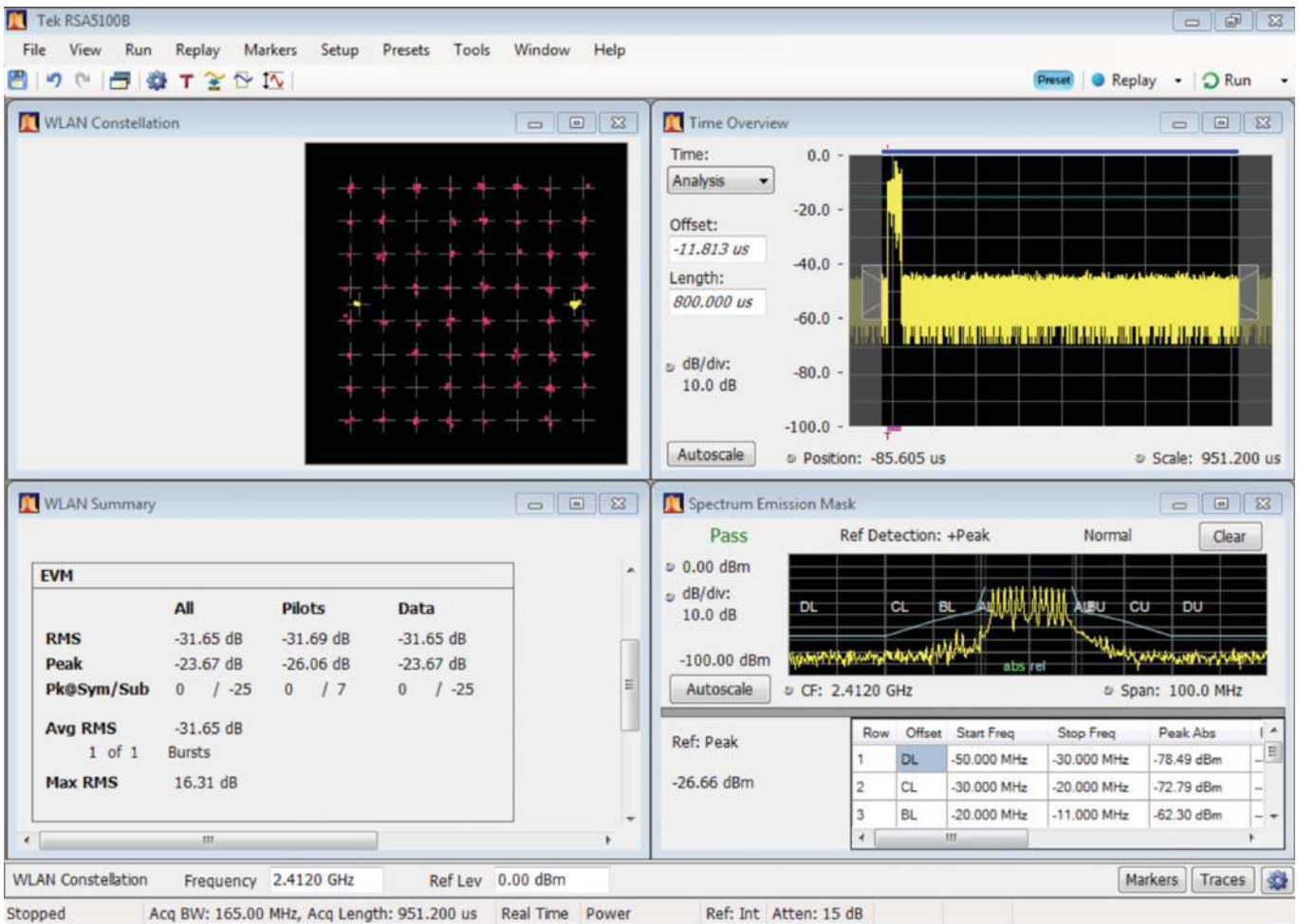

Figure 4-1. 802.11g WLAN transmitter test plots for a 20 MHz channel with 64QAM modulation.

Data Communications: WLAN

Wireless local area networks have become ubiquitous in the last decade as computing has become pervasive in the office, the home, and in personal communications. From the original specifications for Wi-Fi as the IEEE 802.11 standard in the 2.4 GHz industrial, scientific, and medical (ISM) unlicensed frequency band, Wi-Fi has undergone more than a half dozen revisions and progressed from a 2 Mb/s channel to multiple channels with more than 1 Gb/s throughput. Frequency bands now include 2.4 GHz, 3.6 GHz, 5 GHz, and 60 GHz. Currently the most popular variants are 802.11g (2.4 GHz), 802.11n (2.4 and 5 GHz), and 802.11ac (5 GHz). The 802.11g standard (2003) uses a single data stream of up to 54 Mb/s, with OFDM modulation of the packet information in a 20 MHz channel.

Up to 14 channels are available in the 2.4 GHz band. The 802.11n standard (2009) uses up to 4 MIMO data streams with either 20 MHz or 40 MHz channel bandwidth, and with 4 antennas and 40 MHz channels can achieve up to 600 Mb/s. The 802.11ac standard (2013) uses up to 8 MIMO data streams with 20, 40, 80, or 160 MHz channel bandwidth, and can achieve a maximum data rate of up to 6.77 Gb/s using 8 antennas and a 160 MHz channel bandwidth. The latter two standards use a variety of modulation types depending on the channel configurations. A new standard, 802.11ad, also known as WiGig, has recently been approved and will allow operation in the 60 GHz band. Another specification currently in draft, 802.11ah, will provide extended range Wi-Fi in the sub-1 GHz band at data rates of 100 kb for low power transmissions.

Testing WLAN transmission with the newer standards can present some challenges. There are optional implementations for channel bandwidth, modulation type, and the number of spatial streams. In 802.11ac, for example, required parameters are 80 MHz channel bandwidth, one spatial stream, 64QAM modulation, and 5/6 coding with a long guard interval. Optional parameters in the same standard allow 160 MHz channel bandwidth, 8 spatial streams, 256QAM modulation, and 5/6 coding with a short guard interval. A spectrum analyzer should have a real-time bandwidth of 120 MHz for testing an 80 MHz WLAN channel to measure transmitter spectrum emission mask tests, unless there is some external trigger method that allows triggering outside the IF bandwidth. Similarly, for a 160 MHz WLAN channel a 240 MHz bandwidth is required (although the 160 MHz channels may be implemented as two non-contiguous 80 MHz channels). A test instrument should also have good enough linearity and noise specifications to permit measuring the very low EVM that is required for implementation of 256QAM modulation; since the device EVM should be < -32 dBm for 256QAM 5/6 coding, a spectrum analyzer should be at least 10 dB better than that, or < -42 dBm in order to accurately measure the signal without contributing distortion. Finally, for testing of multiple spatial streams the test equipment should have up to 8 independent capture channels that are synchronized to permit phase-accurate measurements from multiple antennas.

Tektronix real-time spectrum analyzers at the low end have a 40 MHz real-time bandwidth, which is adequate for characterization and decoding of 40 MHz WLAN channels. It is possible to synchronize these instruments, so multiple WLAN spatial channels can be captured and analyzed. Wi-Fi transmitters can also be characterized by spectrum emission mask testing for wider channels than 40 MHz, since wide real-time bandwidth is not needed for this type of test, provided that some method of triggering on signal bursts is available, as discussed earlier. The higher-end Tektronix spectrum analyzers have a real-time bandwidth of 165 MHz, which is adequate for full characterization of 160 MHz WLAN channels. The RSA5100B has a residual EVM spec of -49 dBm, which is more than adequate for testing complex modulation such as 256QAM. Figure 4-1 shows some of the WLAN characterization measurement possible using SignalVu WLAN standards measurement software.

See Tektronix Publication 37W-29447-0, "Wi-Fi: Overview of the 802.11 Physical Layer and Transmitter Measurements" for additional information.

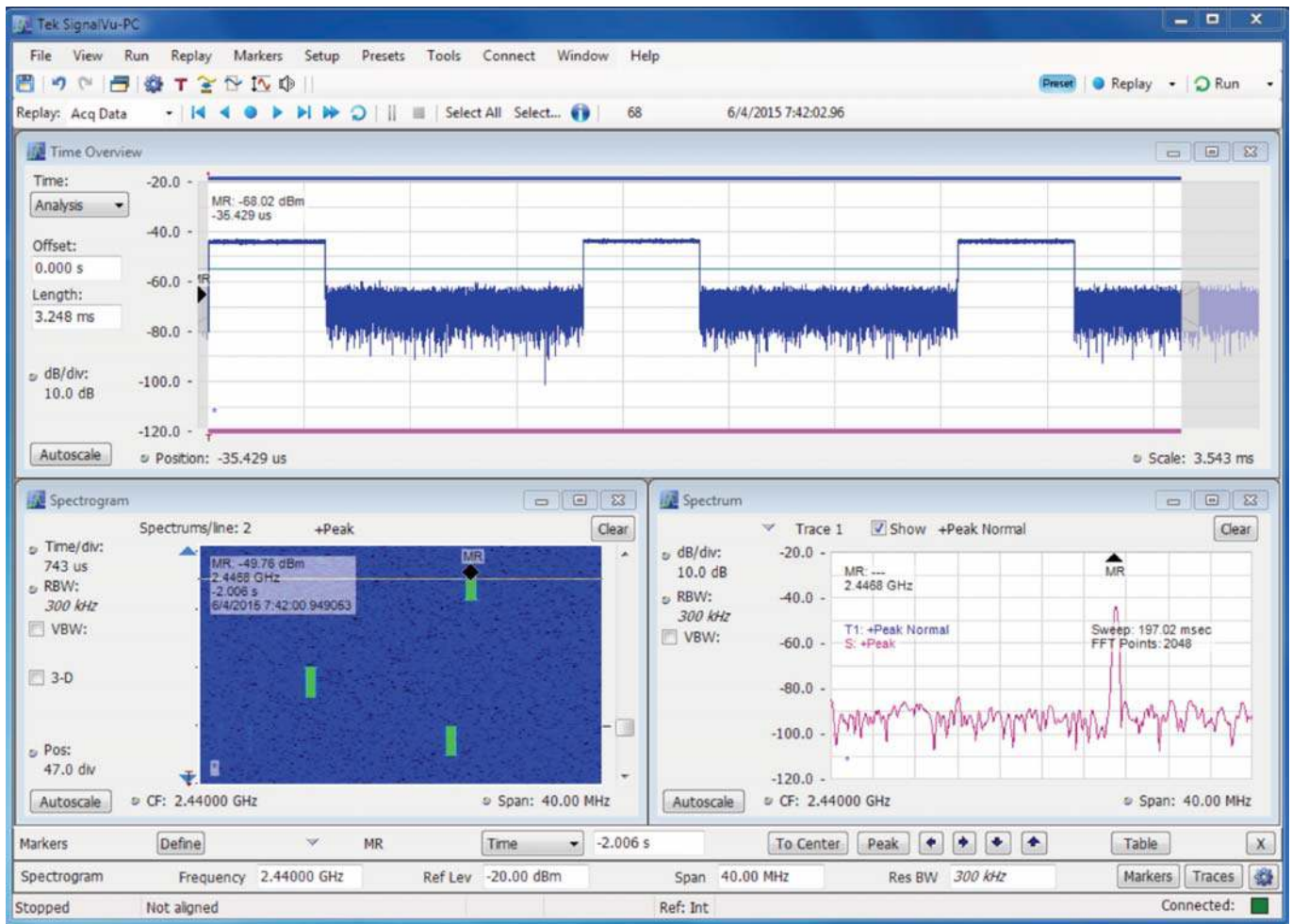

Figure 4-2. Bluetooth spectrogram (color coded spectra with time on the vertical axis) for DH1 packets with a PRBS9 payload, with frequency hopping enabled. A line spectrum is shown at the marker in the spectrogram.

Data Communications: WPAN

Wireless personal area networks are designed to replace low speed electrical connections over short distances (< 10 m). Bluetooth is the best known and most widely deployed personal area network, and is used for connecting electronics such as mobile phones and headsets over short distances. It is expected to be widely used for connecting devices in the Internet of Things. It is based on the IEEE 802.15.1 standard, but the standard is now maintained by the Bluetooth SIG. Bluetooth signals are in the 2.4 GHz ISM band, from 2.400 – 2.4835 GHz. The initial Bluetooth specification used 79 channels with 1 MHz spacing; the current Bluetooth 4.0

specification (2010) uses 40 channels with 2 MHz spacing for Bluetooth Low Energy. Bluetooth Basic Rate (BR) has a data rate of 1 Mb/s and uses Gaussian frequency shift keying (GFSK) modulation. Enhanced Data Rate (EDR) uses pi/4-DPSK modulation (2 Mb/s) or 8DPSK modulation (3 Mb/s) for data; the header is still modulated using GFSK. Bluetooth Low Energy (LE) (marketed as Bluetooth Smart) uses the same spectrum but has 40 2 MHz channels with a bit rate of 1 Mb/s each using GFSK modulation, and is limited to low power (10 mW) operation. Both Bluetooth and Bluetooth Smart use adaptive frequency hopping to minimize interference, although the details are different.

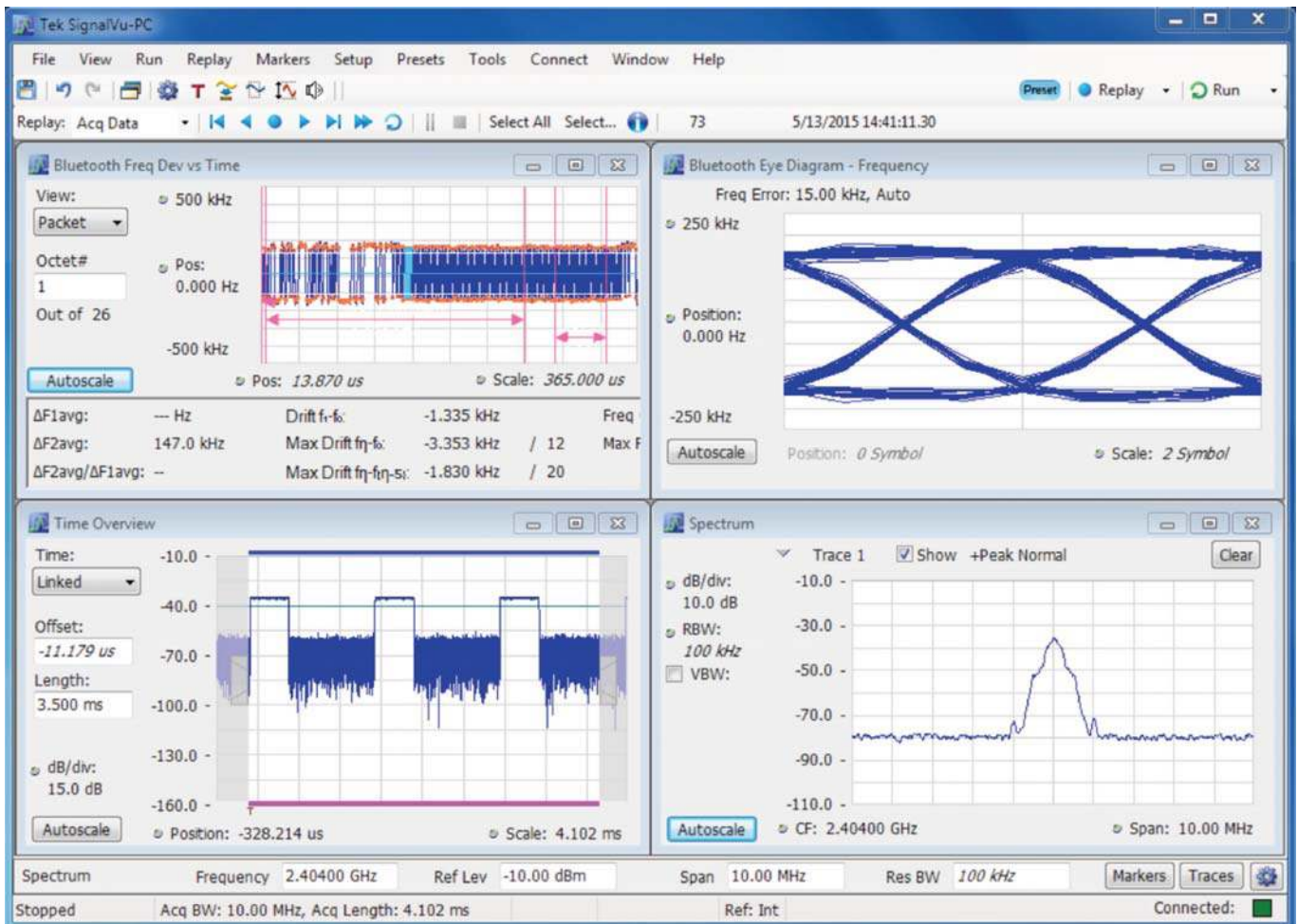

Figure 4-3. Bluetooth Basic Rate RF analysis on the RSA306 using DH1 packets. Shown are the time overview and spectrum for packet transmission, and frequency deviation for GFSK modulation.

Since Bluetooth has a relatively slow radio interface (maximum data rate ~ 3 Mb/s), RF analysis can be done using many types of instrumentation. Frequency hopping takes place at 1600 hops/s. A spectrum analyzer must have sufficiently low noise and a low jitter clock to do accurate modulation analysis. Software presets for modulation types and data rates, such as those available in SignalVu, can make the job of analyzing Bluetooth radios much easier.

In addition to the Bluetooth short distance wireless protocol, another protocol marketed as Zigbee has recently received attention as an even lower rate, lower power communications standard for connecting low data rate sensors and devices. IEEE 802.15.4 (2003) specifies a direct sequence spread spectrum (DSSS) protocol operating in the 868/915 MHz frequency bands at 20 or 40 kbit/s, and in the 2.45 GHz frequency band at 250 kbit/s. The latest version of the

standard, IEEE 802.15.4e (2012), has added several new frequency bands, modulation formats, and bit rates. General modulation test software on any real-time spectrum analyzers can provide information on the wireless link. Protocol specific software can add convenience of use for automatic determination of modulation type, bit rate, etc.

Another protocol that also uses IEEE 802.15.4 radios is 6LoWPAN, defined by the IETF (Internet Engineering Task Force) in RFC 6282. This protocol uses wireless radios to provide IPv6 internet connectivity to devices at low data rates. Although there is not much difference in the radio link from Zigbee, higher protocol layers are quite different and are oriented to providing internet connectivity. Testing of the physical layer is similar to Zigbee. For these low data rates and narrow channels, a portable spectrum analyzer such as the RSA306 is adequate for RF testing.

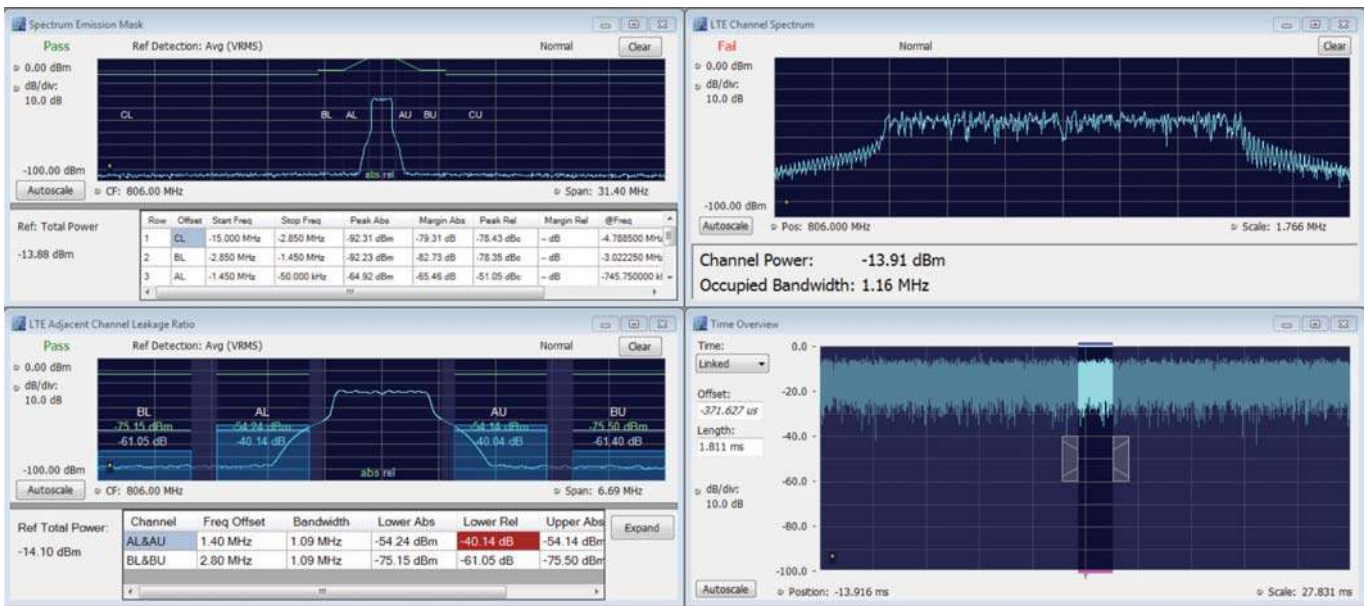

Figure 4-4. LTE emissions testing showing Spectrum Emission Mask and Adjacent Channel Leakage Ratio (ACLR).

Voice and Data Communications: Cellular Radio

A large share of modern RF data transmission now takes place on cellular smart phones. Although the radio interface is just a small part of the cell infrastructure, it determines to a large extent what the user experience will be for hand-held data communications. LTE is the 4G upgrade path for both GSM/UMTS and CDMA2000 networks. RF transmission is specified in 3GPP documentation (TS 36-104 version 12.5.0 Release 12). LTE transmission is standardized on many different frequencies depending on the country; in North America 700, 750 800, 850, 1900, 1700/2100, 2500, and 2600 MHz are used. Allowed spectrum for cells is 1.4, 3, 5, 10, 15, and 20 MHz in the current standard. Peak download rates are 299.6 Mb/s, and peak upload rates are 75.4 Mb/s using 20 MHz of spectrum and 4 x 4 MIMO antennas. OFDMA modulation is used for the downlink and SC-FDMA modulation is used for the uplink.

Testing of LTE transmitters involves primarily verification of power levels and verifying that there are not any unwanted emissions outside the band being used. Shown in Figure 4-4 is a test for Adjacent Channel Leakage Ratio for an LTE base station. Although channels are relatively narrow compared to other wireless technologies, measurement require well-calibrated spectrum analyzers with flat frequency response. Automated measurements using instrument software can greatly aid efficiency of measurements.

Radio Communications

More and more of the control and operation of modern radio communications are controlled by software. Digital circuits are replacing analog functions for dynamic operation of modulation, power, channel control, and channel loading. These modern radios can change power, frequency, modulation, coding, and statistics rapidly over time.

The combination of DPX Spectrum and FMT provide a powerful and unique capability for radio debug. DPX can discover unusual transient events such as impulse noise caused by software faults or other low-level spectrum noise while the FMT can be set up to isolate those events. Using the external trigger output in conjunction with the FMT allows you to trigger other instruments. Triggering oscilloscopes and logic analyzers enables you to isolate events deep into your block diagram so that the root cause can be isolated. Tektronix iView capability and Mixed-Signal Oscilloscopes allow for the accurate time alignment and display of analog and digital signals to with picosecond accuracy. Subroutines and lines of code can be time correlated to the actual spectrum event of interest.

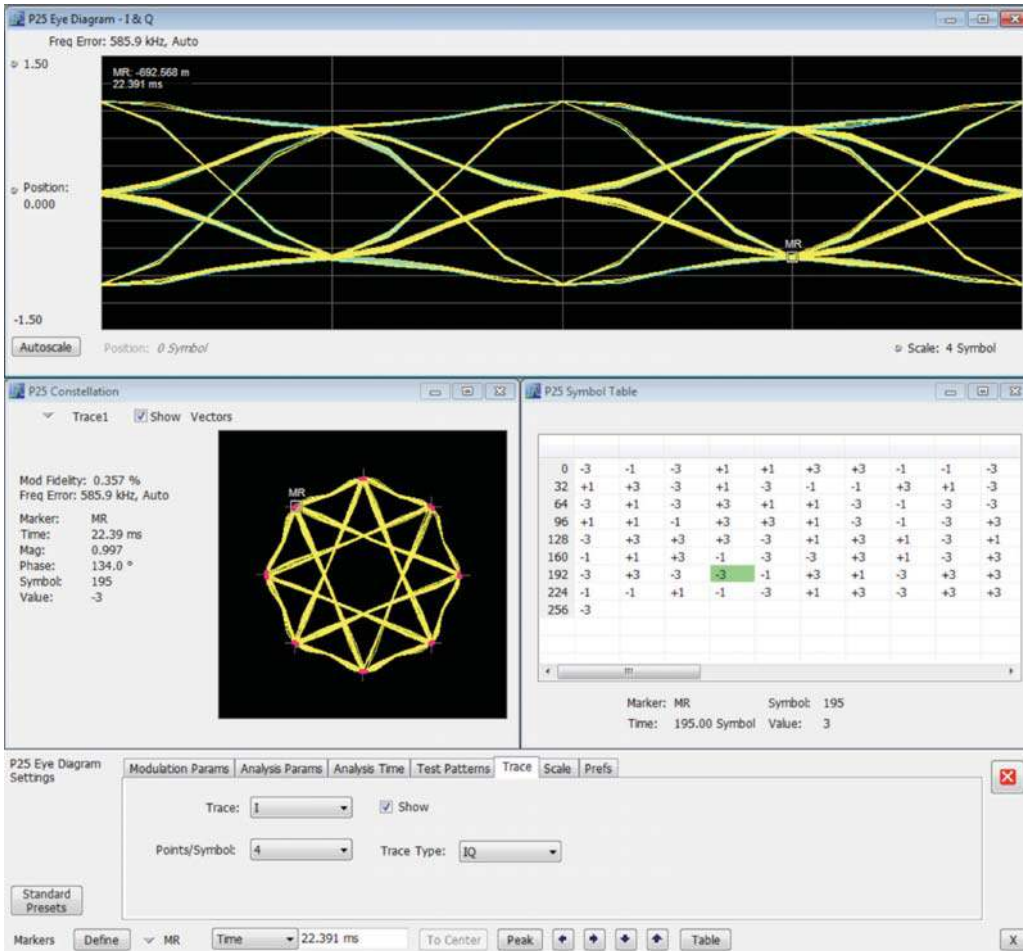

Figure 4-5. P25 radio symbol decode with constellation diagram.

Public safety radio communications have moved to the digital domain since the 1990s due to the limitations of analog radios. In the U.S., Project 25 has evolved as a standard for two-way wireless communications for public safety, security, public service, and commercial applications. Standards are published by the Telecommunications Industry Association (TIA), and stipulate compliance requirements so that different radios can interoperate. Phase 1 radios use continuous 4-level FM modulation (C4FM) at 4.8kbaud and 2 bits/symbol for digital transmission. Receivers are designed to demodulate CQPSK (compatible quadrature phase shift keying) signals, which use only 6.25 kHz of bandwidth, as well as C4FM. Phase 2 specifications are designed to improve spectrum utilization to accommodate additional transmitters in a trunking system, and use a TDMA (time division multiple access) scheme.

P25 radio testing is again a low bandwidth application, but requires stringent frequency stability in test equipment to measure adherence to standards. Very stable oscillators can be used with Tektronix RTSAs to insure testing to standards.

There are several application notes and white papers available from Tektronix on using the RTSA for radio communications applications:

- 37W-19680 Software Defined Radio Testing Using the Real-Time Spectrum Analyzers
- 37W-30665 Testing APCO Project 25 Transmitters with Tektronix Solutions

For more information on Tektronix solutions for radio communications, visit the web: <http://www.tek.com/application/satellite-radio-test-equipment>

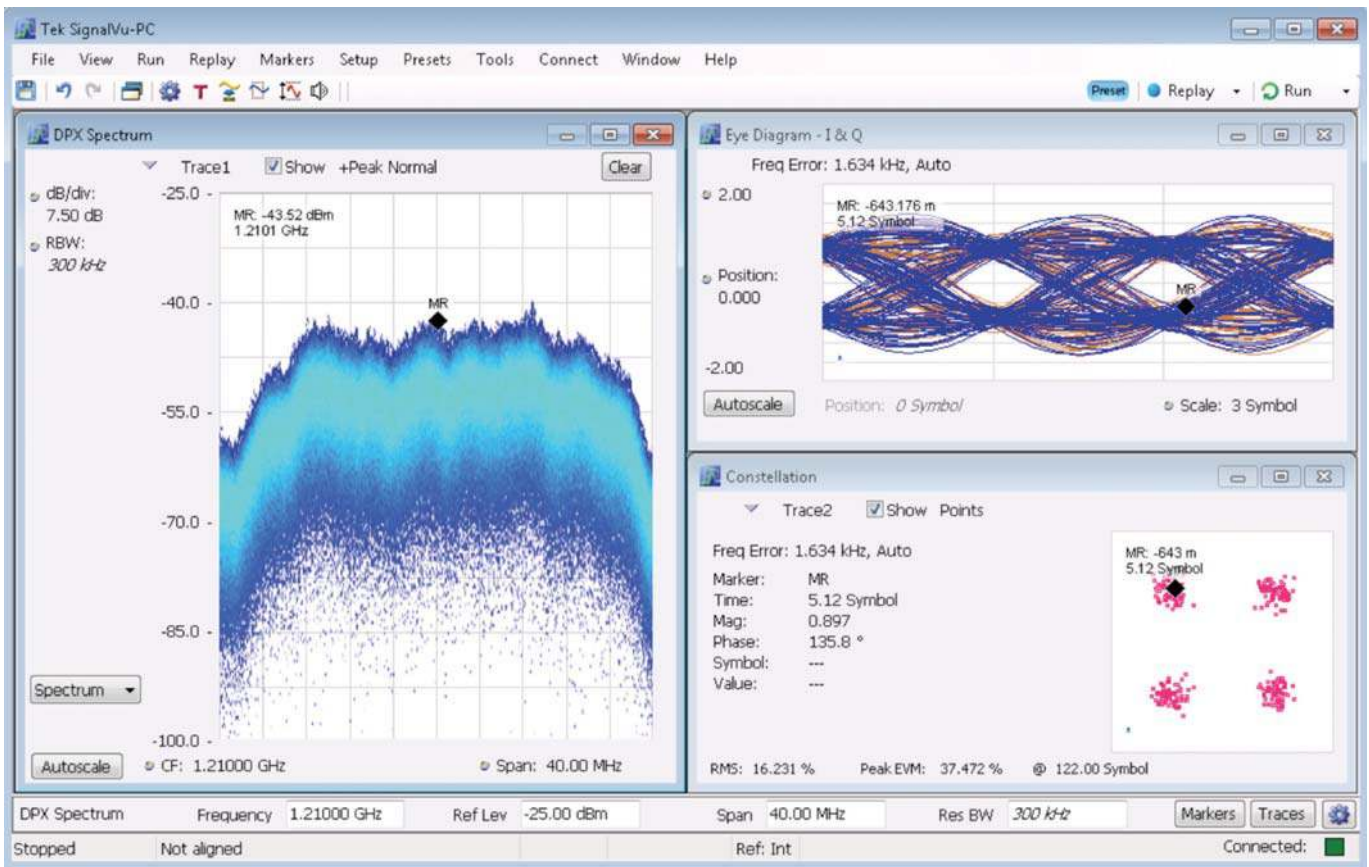

Figure 4-6. Satellite C-band DVB-S video transmission in a 30 MHz bandwidth using QPSK modulation at 29.27 Msymbols/s.

Video Applications

Digital RF is used for several applications in video broadcast. Broadcast material is distributed via satellite using DVB-S and DVB-S2 formats, and digital video is broadcast using the DVB-T format. Standards are published by ETSI (European Telecommunications Standards Institute, www.etsi.org). DVB-S and DVB-S2 are now routinely used for satellite video transmission, and use BPSK, QPSK, 8PSK, 16APSK, and 32APSK modulation (most commonly QPSK and 8PSK).

DVB-T is used for wireless broadcast of terrestrial video, and is now used by more than 70 countries. Shown in Figure 4.6 is an eye pattern and constellation diagram for a decoded QPSK DVB-S signal (29.270 Msymbol/s) that was taken from a C-band satellite transmission at 5150 MHz (downconverted to 1210 MHz) from the A&E Network.

The Tektronix RSA306 low cost USB3 real-time spectrum analyzer can be used to do monitoring of video transmission at multiple locations with remote reporting of error measurements through the API.

Spectrum Management and Interference Finding

Whether you are securing a facility or protecting your spectrum investment, interference must be mitigated. The detection of low-level and intermittent interference in the presence of larger signals and the characterization of impulsive noise are not possible with any certainty using most spectrum analyzer tools.

With DPX displaying Live RF, you will see signals you never knew existed. RTSAs will change the way you search and discover elusive signals. With industry-leading performance for combined bandwidth and dynamic range, RTSAs are the only spectrum analyzers specified with a 100% probability of detecting signals within a band of interest.

Frequency Mask Trigger (FMT) enables the RTSA to trigger on low-level signals or impulses with a 100% probability for capture and analysis.

For the latest information on spectrum management from Tektronix, visit the web: <http://www.tek.com/application/spectrum-management>

Device Testing

Voice communications in mobile communications tend to operate at some level of steady traffic state. As high rate data services become integrated into modern radio communication standards, the output power needs to be rapidly adapt to the changing load. Modulation quality, spectral regrowth, and power efficiency are a constant trade-off in amplifier design.

Whether advances in linearization are driven by the need for better efficiency, reduced cost, or performance, various digital techniques using some form of adaptive digital predistortion (DPD) have become common in cellular amplifier design.

These designs are susceptible to memory effects, bias feed through, and other transient spectral regrowth abnormalities.

With the ability to reveal the existence of memory effects using DPX Spectrum, the RTSA can provide unique insight for amplifier designers. Add the capability of correlated multi-domain analysis for amplitude statistics (CCDF), modulation quality (EVM), and Adjacent Channel Power (ACP) analysis, and the RTSAs provides invaluable insight for amplifier designers.

Learn more about the characterization of modern amplifiers with this application note:

- 37W-19560 Troubleshooting and Characterizing Wide Band RF Systems Using the Real-Time Spectrum Analyzers.

Radar

Integration of pulse measurements into a single tool for time and frequency domain simplifies radar testing and improves test reproducibility. The RTSA has the combined test capability that replaces several common tools used in radar transmitter test analysis (oscilloscopes, spectrum analyzers, vector analyzers, power meters, and peak-power meters). In addition, the Digital Phosphor Display (DPX) can display interference components and the products of non-linearities that go undetected with other tools.

The application note below is available from Tektronix for information on using the RTSA to test radars:

- 37W-20229 Advanced Radar Testing with the Real-Time Spectrum Analyzer

For the latest information on radar test solutions from Tektronix, visit the web: <http://www.tek.com/application/radar-test-and-electronic-warfare>

Chapter 5: Terminology

Glossary

Acquisition - An integer number of time-contiguous samples.

Acquisition Time - The length of time represented by one acquisition.

Amplitude - The magnitude of an electrical signal.

Amplitude Modulation (AM) - The process in which the amplitude of a sine wave (the carrier) is varied in accordance with the instantaneous voltage of a second electrical signal (the modulating signal).

Analysis Time - A subset of time-contiguous samples from one block, used as input to an analysis view.

Analysis View - The flexible window used to display real-time measurement results.

Carrier - The RF signal upon which modulation resides.

Carrier Frequency - The frequency of the CW component of the carrier signal.

Center Frequency - The frequency corresponding to the center of a frequency span of a spectrum the analyzer display.

CZT-Chirp-Z transform - A computationally efficient method of computing a Discrete Fourier Transform (DFT). CZTs offer more flexibility for example in selecting the number of output frequency points than the conventional FFT at the expense of additional computations.

CW Signal - Continuous wave signal. A sine wave.

dBfs - A unit to express power level in decibels referenced to full scale. Depending on the context, this is either the full scale of the display screen or the full scale of the ADC.

dBm - A unit to express power level in decibels referenced to 1 milliwatt.

dBmV - A unit to express voltage levels in decibels referenced to 1 millivolt.

Decibel (dB) - Ten times the logarithm of the ratio of one electrical power to another.

DFT-Discrete Fourier transform - A mathematical process to calculate the frequency spectrum of a sampled time domain signal.

Display Line - A horizontal or vertical line on a waveform display, used as a reference for visual (or automatic) comparison with a given level, time, or frequency.

Distortion - Degradation of a signal, often a result of nonlinear operations, resulting in unwanted frequency components. Harmonic and intermodulation distortions are common types.

DPX - Digital Phosphor analysis - A signal analysis and compression methodology that allows the live view of time-changing signals allowing the discovery of rare transient events.

DPX Spectrum - DPX technology applied to spectrum analysis. DPX Spectrum provides a Live RF view as well as the observation frequency domain transients.

Dynamic Range - The maximum ratio of the levels of two signals simultaneously present at the input which can be measured to a specified accuracy.

FFT - Fast Fourier Transform - A computationally efficient method of computing a Discrete Fourier Transform (DFT). A common FFT algorithm requires that the number of input and output samples are equal and a power of 2 (2,4,8,16,...).

Frequency - The rate at which a signal oscillates, expressed as hertz or number of cycles per second.

Frequency Domain View - The representation of the power of the spectral components of a signal as a function of frequency; the spectrum of the signal.

Frequency Drift - Gradual shift or change a signal frequency over the specified time, where other conditions remain constant. Expressed in hertz per second.

Frequency Mask Trigger - A flexible real-time trigger based on specific events that occur in the frequency domain. The triggering parameters are defined by a graphical mask.

Frequency Modulation (FM) - The process in which the frequency of an electrical signal (the carrier) is varied according to the instantaneous voltage of a second electrical signal (the modulating signal).

Frequency Range - The range of frequencies over which a device operates, with lower and upper bounds.

Frequency Span - A continuous range of frequencies extending between two frequency limits.

Marker - A visually identifiable point on a waveform trace, used to extract a readout of domain and range values represented by that point.

Modulate - To vary a characteristic of a signal, typically in order to transmit information.

Noise - Unwanted random disturbances superimposed on a signal which tend to obscure that signal.

Noise Floor - The level of noise intrinsic to a system that represents the minimum limit at which input signals can be observed; ultimately limited by thermal noise (kTB).

Noise Bandwidth (NBW) - The exact bandwidth of a filter that is used to calculate the absolute power of noise or noise-like signals in dBm/Hz.

Probability of Intercept - The certainty to which a signal can be detected within defined parameters.

Real-Time Bandwidth - The frequency span over which real-time seamless capture can be performed, which is a function of the digitizer and the IF bandwidth of a Real-Time Spectrum Analyzer.

Real-Time Seamless Capture - The ability to acquire and store an uninterrupted series of time domain samples that represent the behavior of an RF signal over a long period of time.

Real-Time Spectrum Analysis - A spectrum analysis technique based on Discrete Fourier Transforms (DFT) that is capable of continuously analyzing a bandwidth of interest without time gaps. Real-Time Spectrum Analysis provides 100% probability of display and trigger of transient signal fluctuations within the specified span, resolution bandwidth and time parameters.

Real-Time Spectrum Analyzer - Instrument capable of measuring elusive RF events in RF signals, triggering on those events, seamlessly capturing them into memory, and analyzing them in the frequency, time, and modulation domains.

Reference Level - The signal level represented by the uppermost graticule line of the analyzer display.

Resolution Bandwidth (RBW) - The width of the narrowest measurable band of frequencies in a spectrum analyzer display. The RBW determines the analyzer's ability to resolve closely spaced signal components.

Sensitivity - Measure of a spectrum analyzer's ability to display minimum level signals, usually expressed as Displayed Average Noise Level (DANL).

Spectrogram - Frequency vs. Time vs. amplitude display where the frequency is represented on x-axis and time on the y-axis. The power is expressed by the color.

Spectrum - The frequency domain representation of a signal showing the power distribution of its spectral component versus frequency.

Spectrum Analysis - Measurement technique for determining the frequency content of an RF signal.

Vector Signal Analysis - Measurement technique for charactering the modulation of an RF signal. Vector analysis takes both magnitude and phase into account.

Acronym Reference

ACP:	Adjacent Channel Power
ADC:	Analog-to-Digital Converter
AM:	Amplitude Modulation
BH4B:	Blackman-Harris 4B Window
BW:	Bandwidth
CCDF:	Complementary Cumulative Distribution Function
CDMA:	Code Division Multiple Access
CW:	Continuous Wave
dB:	Decibel
dBfs:	dB Full Scale
DDC:	Digital Downconverter
DFT:	Discrete Fourier Transform
DPX:	Digital Phosphor Display, Spectrum, etc.
DSP:	Digital Signal Processing
EVM:	Error Vector Magnitude
FFT:	Fast Fourier Transform
FM:	Frequency Modulation
FSK:	Frequency Shift Keying
IF:	Intermediate Frequency
IQ:	In-Phase Quadrature
LO:	Local Oscillator
NBW:	Noise Bandwidth
OFDM:	Orthogonal Frequency Division Multiplexing
PAR:	Peak-Average Ratio
PM:	Phase Modulation
POI:	Probability of Intercept
PRBS:	Pseudorandom Binary Sequence
PSK:	Phase Shift Keying
QAM:	Quadrature Amplitude Modulation
QPSK:	Quadrature Phase Shift Keying
RBW:	Resolution Bandwidth
RF:	Radio Frequency
RMS:	Root Mean Square
RTSA:	Real-Time Spectrum Analyzer
SA:	Spectrum Analyzer
VSA:	Vector Signal Analyzer

Contact Tektronix:

ASEAN / Australasia (65) 6356 3900
Austria 00800 2255 4835
Balkans, Israel, South Africa and other ISE Countries +41 52 675 3777
Belgium 00800 2255 4835
Brazil +55 (11) 3759 7627
Canada 1 800 833 9200
Central East Europe and the Baltics +41 52 675 3777
Central Europe & Greece +41 52 675 3777
Denmark +45 80 88 1401
Finland +41 52 675 3777
France 00800 2255 4835
Germany 00800 2255 4835
Hong Kong 400 820 5835
India 000 800 650 1835
Italy 00800 2255 4835
Japan 81 (3) 6714 3010
Luxembourg +41 52 675 3777
Mexico, Central/South America & Caribbean 52 (55) 56 04 50 90
Middle East, Asia, and North Africa +41 52 675 3777
The Netherlands 00800 2255 4835
Norway 800 16098
People's Republic of China 400 820 5835
Poland +41 52 675 3777
Portugal 80 08 12370
Republic of Korea 001 800 8255 2835
Russia & CIS +7 (495) 6647564
South Africa +41 52 675 3777
Spain 00800 2255 4835
Sweden 00800 2255 4835
Switzerland 00800 2255 4835
Taiwan 886 (2) 2656 6688
United Kingdom & Ireland 00800 2255 4835
USA 1 800 833 9200

Rev. 0415

For Further Information

Tektronix maintains a comprehensive, constantly expanding collection of application notes, technical briefs and other resources to help engineers working on the cutting edge of technology. Please visit www.tektronix.com and www.keithley.com.

Copyright © 2015, Tektronix. All rights reserved. Tektronix products are covered by U.S. and foreign patents, issued and pending. Information in this publication supersedes that in all previously published material. Specification and price change privileges reserved. TEKTRONIX and TEK are registered trademarks of Tektronix, Inc. All other trade names referenced are the service marks, trademarks or registered trademarks of their respective companies.

06/15 EA/

37W-17249-5

